

www.wackerneuson.com

0203599en	006
11.2008	

Floor saw

BFS 1345
B, BZ

Operator's manual

Important note

EPA-certified engine

This machine is equipped with an EPA-certified engine.

Relevant details can be found in the instructions of the engine manufacturer.

Warning

The engine's exhaust fumes contain chemicals which are known to the State of California to cause cancer, congenital defects or other reproductive anomalies.



1. Foreword

For your own safety and protection from bodily injuries, carefully read, understand and follow the safety information in this manual.

Please operate and maintain your Wacker Neuson machine in accordance with the instructions in this operator's manual. Your Wacker Neuson machine will reward you with troublefree operation and a high degree of availability.

Defective components must be replaced immediately.

All rights, especially the right for copying and distribution, are reserved

Copyright 2008 by Wacker Construction Equipment AG

No part of this publication may be reproduced in any form or by any means, electronic or mechanical, including photocopying, without express permission in writing from Wacker Construction Equipment AG.

Any type of reproduction, distribution or saving on data carriers of any type or method not authorized by Wacker Neuson represents an infringement of valid copyrights and will be prosecuted. We expressly reserve the right to make technical modifications - even without special notice - which aim at further improving our machines or their safety standards.

Table of contents

1. Foreword	5
2. Safety information	8
2.1 General instructions	8
2.2 Operation	8
2.3 Safety checks	10
2.4 Maintenance	11
2.5 Transport	11
2.6 Maintenance checks	11
3. Technical data	12
4. Description	13
4.1 Application	13
4.2 Maximum permissible tilt	13
4.3 Functional description	14
4.4 General instructions for use for diamond-edged cutting blades	15
5. Transport to the worksite	16
6. Operation	17
6.1 Adjusting the handle	17
6.2 Adjusting / Aligning the guide wheel	18
6.3 Cutting depth setting	19
6.4 Depth of cut indicator	19
6.5 Water tank	20
6.6 Parking brake	21
6.7 Assembling the cutting blade	22
6.8 Disassembling the cutting blade	23
6.9 Checking the motor before starting	24
6.10 Starting the engine	25
6.11 Engine operation	27
6.12 Switch off the engine	28

7. Maintenance	29
7.1 Maintenance schedule	29
7.2 Checking engine oil level	30
7.3 Changing the engine oil	30
7.4 Cleaning the air cleaner	31
7.5 Cleaning the screws, nuts and bolts	31
7.6 Tightening the belt	32
7.7 Changing the belt	33
7.8 Checking the spark plug	34
8. Signs	35
EC Declaration of Conformity	37
DIN EN ISO 9001 Certificate	39

Safety information

2. Safety information

for floor saws with combustion engine drive

2.1 General instructions

- 2.1.1 Floor saws may only be operated by persons who
- * are at least 18 years of age,
 - * are physically and mentally fit for this job,
 - * have been instructed in operating floor saws and have proved their abilities to the employer and
 - * may be expected to carry out the job they are charged with carefully.
- They must have been assigned to work on the floor saws by the company.
- 2.1.2 Floor saws may only be operated taking the operator's manual of the manufacturer and this safety information into account.
- 2.1.3 The persons charged with the operation of floor saws must be made familiar with the necessary safety measures relating to the machine. In case of extraordinary uses, the employer shall give the necessary additional instructions.
- 2.1.4 This machine generates noise that exceeds the country-specific permissible noise levels (individual rating level). It may therefore be necessary to wear ear protection.

2.2 Operation

- 2.2.1 The function of operation levers or elements must not be influenced or rendered ineffective.
- 2.2.2 Use only cutting blades that are suitable for the peripheral speed or the speed of the machine.
- 2.2.3 Always use the correct cutting blade for the material to be cut.
- 2.2.4 Do not touch hot parts as they can cause burns!
- 2.2.5 Particularly when starting the engine you have to make sure that the cutting blade does not come into contact with anything.
- 2.2.6 Never let the machine run unattended.
- 2.2.7 The operator must not leave the machine during operation.
- 2.2.8 Before the operator leaves the floor saw unattended, he must switch off the engine and take precautions to prevent the machine from slipping or falling over.

Safety information

2.2.9 Open flames and smoking are strictly prohibited in the immediate vicinity of this machine.

2.2.10 The tank lid must be tightly secured. When the motor is switched off, the fuel tap - if there is one - must be closed. When transported over long distances, the tank of gasoline or mixed gasoline driven engines must be completely emptied.



Leaking fuel tanks can lead to explosions and therefore must be replaced immediately.

2.2.11 The tank may only be filled when the motor is switched off and the fuel must not make contact with hot parts or fall on the ground.

2.2.12 Safety in the work area

There may be no electric lines, gas lines, water lines or pipes in the work area.

2.2.13 No operation in closed quarters

Do not operate the machine in closed quarters!

In partially closed rooms such as tunnels, drifts or deep trenches, ensure sufficient ventilation by, for example, providing a powerful exhaust air fan.

Danger of poisoning! Do not inhale exhaust fumes. They contain toxic carbon monoxide that can lead to unconsciousness or death.

2.2.14 Floor saws must be operated in wet-cutting operation to prevent harmful particulate matter from developing. During wet-cutting operation, a sufficient water supply must always be ensured.

2.2.15 Do not operate this machine in areas where explosions may occur.

2.2.16 Prior to working near easily combustible material, ensure that supplies of water or a fire extinguisher are readily available for use.

2.2.17 Always wear eye protection, ear protection, working gloves, hard hat, close-fitting clothing and hard-toed shoes during work. Shoes and leg wear must not be open in order to protect the wearer from flying sparks. In the case of dusty ambient air, breathing protection must also be worn.

2.2.18 Prevent the machine from turning to the side in the case of cuts, thrusts, blows or falls. Otherwise, the cutting blade may be damaged. Only cut materials on the edge of the blade.

2.2.19 Prior to commissioning, fix the protective hood in protective position.

2.2.20 During work, no one is to come near the machine.

2.2.21 Prior to making adjustments, the operator must stop the cutting blade.

2.2.22 Work in a calm and composed manner. Prevent risks to others by exercising caution.

2.2.23 Do not process loose materials (e.g. paving stones).

Safety information

2.3 Safety checks

- 2.3.1 Floor saws may only be operated with all safety devices installed.
- 2.3.2 Before starting operation, the operator has to check that all control and safety devices are functioning properly.
- 2.3.3 Prior to starting the cutting operation, the following have to be checked on a daily basis:
 - * Proper condition of the cutting blade.
 - * Tightness of the cutting blade.
 - * Damage and wear of the operating and safety equipment.
- 2.3.4 If defects on the safety devices or other defects impairing the operational safety of machine are observed, the supervisor must be informed immediately.
- 2.3.5 If there are defects jeopardizing operational safety, the machine has to be switched off immediately.

2.4 Maintenance

- 2.4.1 Only use original spare parts. Alterations to this machine, incl. adjustments of the maximum engine speed set by the manufacturer may only be carried out with the express permission of Wacker Neuson. In case of non-observance, all liability shall be refused.
- 2.4.2 Switch off the motor during maintenance work and remove the spark plug terminal cap (if there is one), in order to avoid an unintentional start. This procedure may only be waived if the work cannot be carried out when the motor is switched off.
- 2.4.3 Exercise caution when checking the ignition system. The electronic ignition creates a very high voltage.
- 2.4.4 As soon as maintenance and repair jobs have been completed, all safety devices must be properly reinstalled.
- 2.4.5 It is not permitted to tilt the machine for maintenance work.
- 2.4.6 In order to prevent malfunctions, the floor saw should be cleaned using water after each use.

2.5 Transport

- 2.5.1 Prior to transport, the cutting blade must be removed and the floor saw must be put in the lowest cutting position.
- 2.5.2 For the loading and transportation of floor saws with hoisting gear, suitable sling chains must be secured at the relevant fixing point.
- 2.5.3 Loading ramps must be able to bear the load and be in a stable position. Make sure that no one can be endangered if the machine slips away or tips over, or if machine parts suddenly move upward or downward.
- 2.5.4 When floor saws are being transported in vehicles, precautions have to be taken to ensure that they do not slip and fall over.

2.6 Maintenance checks

- 2.6.1 According to the conditions and frequency of use, floor saws must be checked for safe operation at least once a year by skilled technicians, such as those employed by Wacker Neuson service stations, and repaired if necessary.

Please observe the appropriate rules and regulations valid in your country.

Technical data

3. Technical data

		BFS 1345 AB	BFS 1345 ABZ	BFS 1345 B	BFS 1345 BZ
Item no.		0008764 0610141	0610242	0008909 0610142	0610243
Length x Width x Height	mm (in):	1,160 x 568 x 1,078 (45.67 x 22.36 x 42.44)			
Weight	kg (lb):	95 (209)	96 (212)	95 (209)	96 (212)
Powertrain		From drive motor via belt to cutting blade			
Max. cutting blade diameter	mm (in):	450 (17.72)			
Min. cutting blade diameter	mm (in):	350 (13.78)			
Max. cutting width	mm (in):	12 (0.47)			
Center bore	mm (in):	25.4 (1.00)			
Max. cutting depth	cm (in):	17 (6.69)			
Peripheral blade speed at ø 350 ø 400 ø 450 (at rated engine speed)	m/s (ft/s): m/s (ft/s): m/s (ft/s):	40.3 (132) 46.1 (151) 51.8 (170)			
Operating blade speed (at rated engine speed)	rpm:	2,200			
Water tank capacity	l (gal):	32 (8.45)			
Drive motor		Air-cooled, single-cylinder, four-stroke gasoline engine			
Engine displacement	cm ³ (in ³):	389 (23.73)		404 (24.65)	
Rated speed	rpm:	3,600			
Rated power (*)	kW/HP:	9.6/13		9.9/13.5	
Fuel		Normal gasoline, also unleaded			
Fuel consumption (at rated output)	l/h (gal/h):	4.3 (1.14)			
Fuel tank capacity	l (gal):	6.5 (1.72)		7.0 (1.85)	
Oil capacity	l (gal):	1.1 (0.29)		1.2 (0.32)	
Oil specification		SAE 15W-40			
Spark plug	Type:	NGK BPR6ES			
(*) Corresponds to the installed effective power in accordance with Directive 2000/14/EC					
Sound pressure level at operator's station	L _{PA} :	97 dB(A)			
Weighted effective acceleration value according to EN ISO 5349	m/s ² :	6.2		7.5	

4. Description

4.1 Application

- * Cutting expansion joints in concrete and asphalt surfaces.
- * Repair work on streets, e.g. cutting out damaged areas in asphalt and concrete.
- * Straightening blacktops and concrete surfaces.
- * For demolition jobs and refurbishment of old buildings.
- * Sawing off precast concrete parts.
- * Expansion joints and installation channels in floors.
- * Laying induction loops and cables in signal installations.

4.2 Maximum permissible tilt

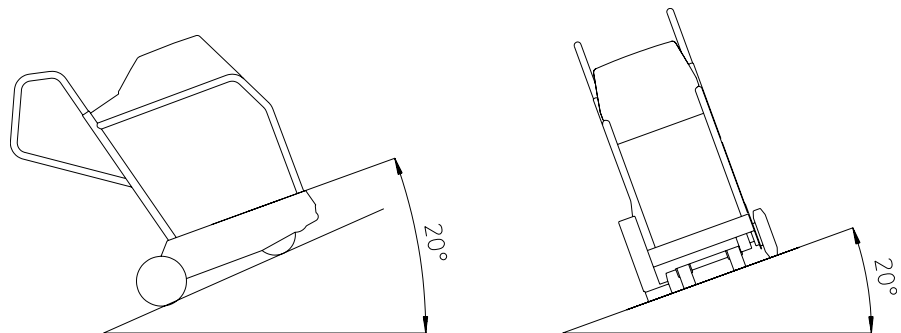

The maximum permissible tilt applies to the engine level.

Description

4.3 Functional description

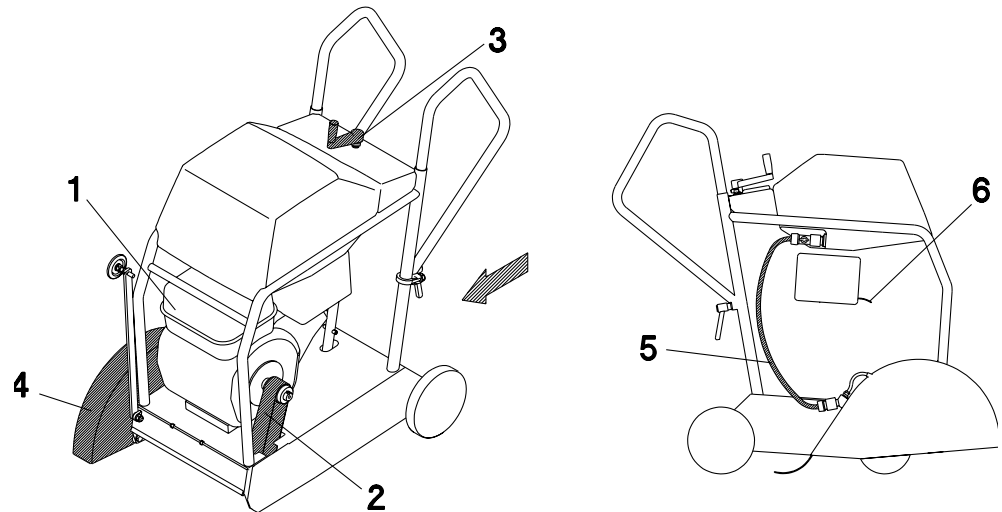

The floor saw must only be operated in a forward direction (see arrow). The drive motor (1) attached to the frame drives the cutting blade via the belt (2).

The cutting blade can be infinitely adjusted by means of a crank handle (3), 1 turn corresponds to a cutting depth adjustment of 5 mm. The cutting blade guard (4) can be swiveled upwards to make it easier to assemble and disassemble the cutting blade.

Furthermore, the cutting blade guard can be connected with the water tank by means of a hose (5) and an adapter.

Wetting the cutting blade with water prevents dust from developing.

The adapter on the water hose allows the connection of an external water supply.

The drive motor speed can be infinitely adjusted by means of the gas throttle lever (6), whereby the optimum cutting blade speed is reached when the drive motor is operated at full throttle.

To facilitate the starting procedure, the drive motor is equipped with a choke.

4.4 General instructions for use for diamond-edged cutting blades

- * Never use a cutting blade with a larger diameter than necessary in order to cut a certain depth.
- * If the cutting blade comes to a standstill, remove it from the cut before starting the machine again. If the cutting blade comes to a standstill in the cut, check whether the belt is tightened adequately. Check the tension screw and make sure that it is tightened properly.
- * Cut in a straight line. Mark the cutting line clearly in such a way that the operational personnel can follow it easily. This is to ensure that the floor saw machine does not need to be redirected from one side to the other (avoid cutting tight curves).
- * Sufficient drive power is essential! When cutting, work at full throttle.
- * Caution on steep tracks and levels! The machine must not exert lateral force against the blade.
- * Never exceed the maximum speeds (imprinted on cutting blade)!
- * Use a suitable diamond-edged cutting blade for the material to be cut (asphalt, concrete ...). Wacker Neuson offers an extensive range of diamond-edged cutting blades in different qualities.
- * Do not cut into the gravel area using diamond-edged cutting blades. When cutting on the edge of the track or when cutting two different materials (cutting in the joint area), uneven wear is possible. Check carefully for irregularities (reinforcements etc.) in the material to be processed. These can overload the cutting blade very quickly. When starting cutting operations, work carefully and with a low down speed.
- * Do not process loose materials (e. g. paving stones).

Transport to the worksite

5. Transport to the worksite

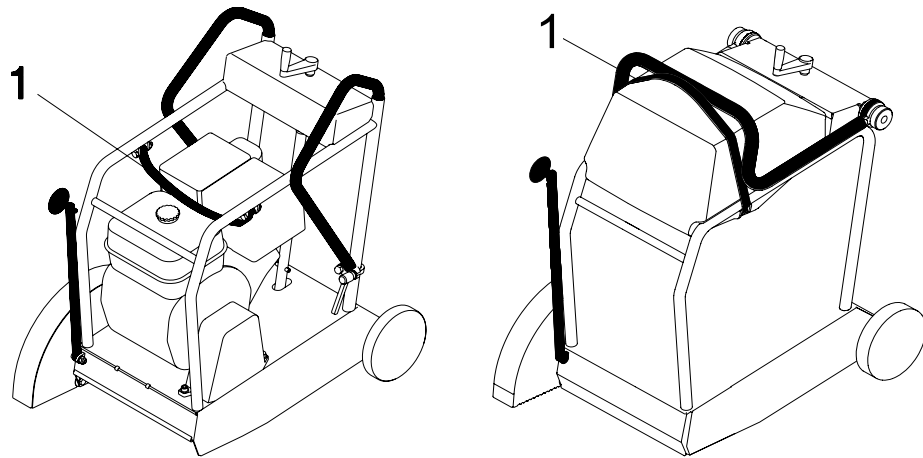

Requirements:

- * When transporting the floor saw, use only suitable hoisting gear with a minimum load-bearing capacity of 150 kg.
- * Always turn off the motor during transportation!
- * Empty the water tank!
- * Remove the cutting blade prior to transport. Set the lowest cutting position on the floor saw.
- * Remove the water tank and attach the hoisting gear on the transport strap (1) for lifting.
- * If you transport the floor saw on the cargo area of a vehicle, strap it down securely on the special safety bar.
- * Fold the guide wheel to the top and the handles to the front (or the stirrup handle to the top).
- * Handles, guide wheel and other operating controls must not be used as attachment points.

Note: Also observe the regulations in the chapter Safety information.

6. Operation

6.1 Adjusting the handle

6.1.1 Handle

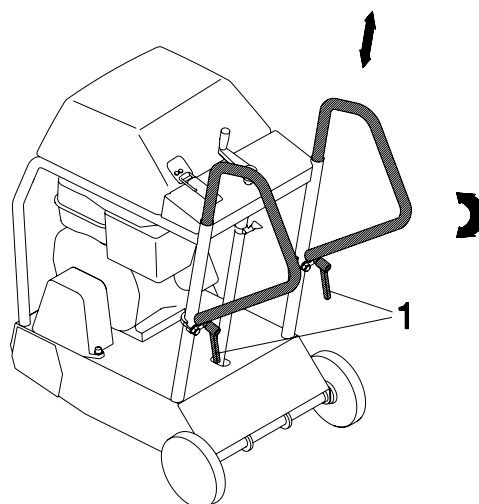

The width and height of the handles can be adjusted according to the use and the body height of the operator. To do this, release the clamping lever (1) and apply it in the new position.

6.1.1 Stirrup handle (alternative version)

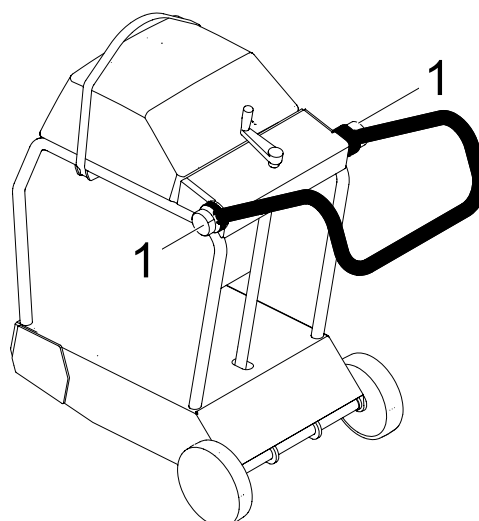

The height of the stirrup handle can be adjusted according to the use and the body height of the operator.

Loosen the knurled screws (1) on both sides, swivel the handle to the desired position and retighten the two knurled screws.

Operation

6.2 Adjusting / Aligning the guide wheel

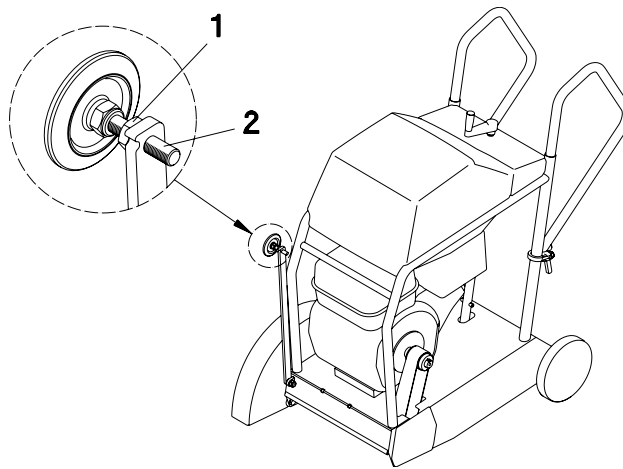

6.2.1 Adjusting the guide wheel

The guide wheel is designed to help the operator in making long, straight cuts. The guide wheel can be exactly adjusted to the cutting blade by loosening the jam nut (1) and turning the screw (2).

6.2.2 Aligning the guide wheel

To do this, make a cut of approx. 2 m length on a flat surface and with the minimum cutting depth. Then pull back the machine without lateral force. Then you can align the guide wheel exactly with the cut.

6.3 Cutting depth setting

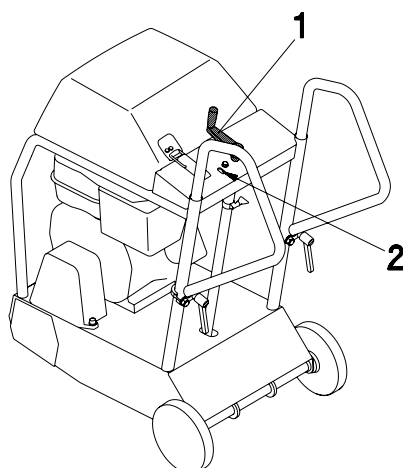

With the crank (1) you can set the cutting depth precisely. One turn changes the cutting depth by exactly 5 mm. Turn the crank in the clockwise direction to increase the cutting depth and turn it in the counterclockwise direction to reduce the cutting depth.

Note: You can also insert the supplied tool into the receptacle (2) near the crank and thus prevent an unintentional change of the cutting depth.

6.4 Depth of cut indicator

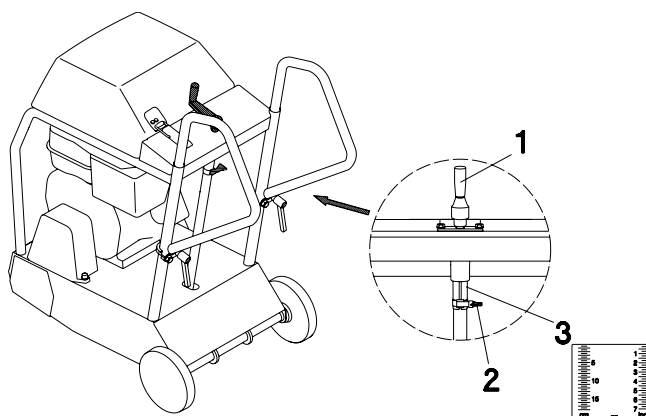

You can use the indicator to check the cutting depth currently set. It features a cm-scale and an inch-scale. You have to adjust it to the diameter of the blade currently installed to obtain the correct value. To do this, turn the crank (1) until the blade touches the ground, loosen the clamp (2) and push the sleeve (3) with the scale up to the bottom of the sleeve. Then tighten the clamp (2) again.

Operation

6.5 Water tank

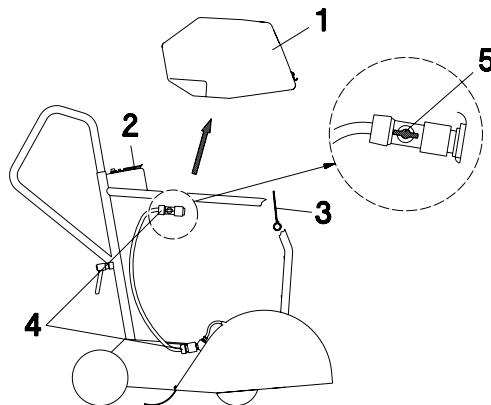

The floor saw features an integrated, removable water tank (1).

To fit the water tank, attach the retaining clamp (2) and tighten it with the strap (3).

To remove the water tank or to attach an external water supply, you can disconnect the hose on two different spots (4).

The amount of water can be regulated or stopped (5).

Note: You should remove the water tank if the machine is connected to an external water supply.

6.6 Parking brake

6.6.1 Integrated parking brake

The machine features an integrated parking brake.

The front wheels are automatically blocked in transport position (lowest cutting position without a cutting blade) or if the maximum cutting depth is exceeded.

6.6.2 Manual parking brake (accessories)

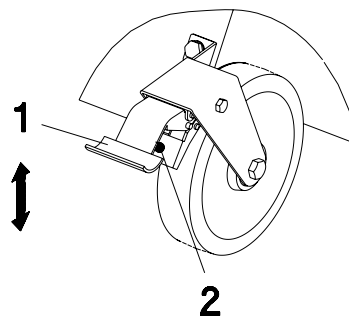

Press the pedal (1) down to block the right rear wheel. Push the pedal upwards for brake release.



Check the tight fit of the parking brake and the setting of the pressure screw (2) at regular intervals. The brake must securely block the wheel at least on a 10° slope. Adjust the pressure screw if necessary.

Operation

6.7 Assembling the cutting blade

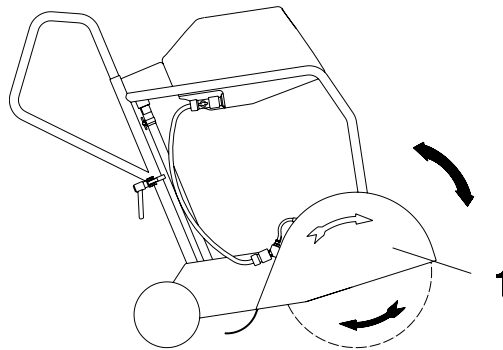

6.7.1 Checking a new cutting blade:

- * The blade type must be suitable for the material to be cut. Observe the peripheral speed, refer to the "Technical data"!
- * The arbor diameter of the cutting blade must precisely fit the shaft to ensure smooth blade running.
- * The cutting blade must be undamaged.



Observe the correct direction of rotation of the cutting blade! That means the rotational direction mark on the cutting blade must correspond with the rotational direction mark on the cutting blade guard.

6.7.2 Proceed as follows for the assembly of the cutting blade:

1. Fold up the cutting blade guard (1).
2. Prior to the assembly of the cutting blade, clean the spring washers and the locking pin and check them for damage.
3. Attach cutting blade and spring washer on the shaft.
4. Tighten the hexagonal bolt firmly. To do this, apply counter pressure on the spanner surfaces of the cutting shaft.
5. Fold down the cutting blade guard.



Starting the machine is only permitted with a water hose connected and the water supply turned on.

6.8 Disassembling the cutting blade

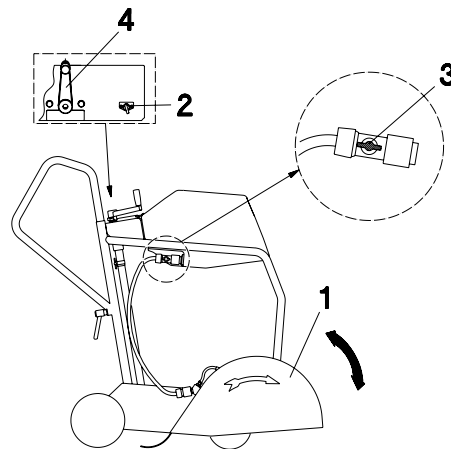

Proceed as follows for the disassembly of the cutting blade:

1. Turn off the engine (2) and the water supply (3).
2. Turn the crank (4) in the counterclockwise direction until the blade is clear of the ground.
3. Fold up the cutting blade guard (1).
4. Loosen the hexagonal bolt. To do this, apply counter pressure on the spanner surfaces of the cutting shaft.
5. Remove the spring washer and the cutting blade.
6. Fold down the cutting blade guard.



Store the spring washer and the hexagonal bolt in a clean place where they cannot become dirty. Assemble both parts for the transport of the machine!

Operation

6.9 Checking the motor before starting

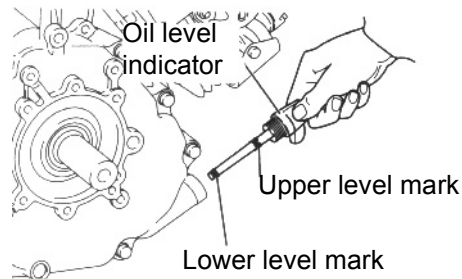

6.9.1 Engine oil

Switch off the engine.

Prior to checking the engine oil level or refilling engine oil, make sure that the engine bolting level is aligned horizontally.

- * Remove the oil filler cap (oil level indicator).
- * If the oil level is below the lower filling mark on the dip stick, add suitable engine oil until the oil reaches the edge of the filler neck.
- * An oil change is required if the engine oil is dirty.
- * Only use high-quality engine oil, see *Technical Data*.



The engine is automatically switched off when the oil level falls below a specific level. If this is the case, the engine can only be started after engine oil has been refilled.

6.9.2 Fuel



Do not smoke during refueling and make sure that there are no open flames or sparks in the immediate vicinity.

Turn off the engine and open the fuel tank cap.

- * Only use leadfree fuel.
- * Close the fuel tap before the fuel tank is filled with fuel.
- * Always use the fuel filter when refilling fuel.
- * Wipe off any spilled fuel before starting the engine.

6.10 Starting the engine



The cutting blade must not be in contact with the ground.

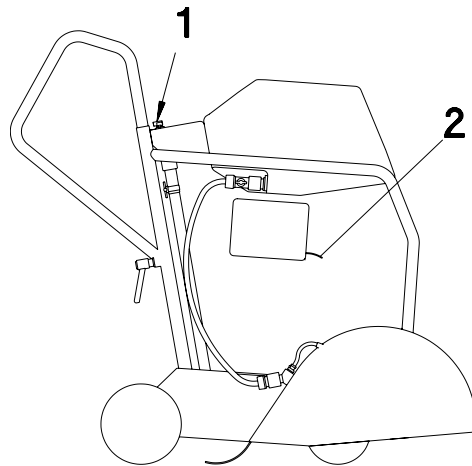

1. Switch the main switch (1) to "I".

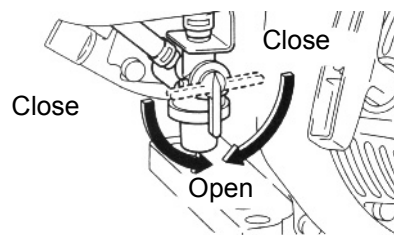

2. Open the fuel tap.

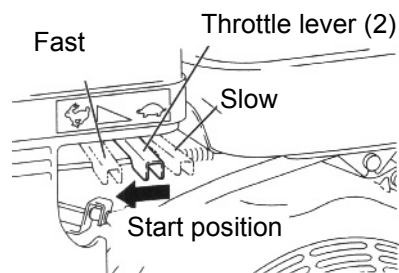

3. Shift the throttle lever (2) to approximately 1/3 of the full throttle position.

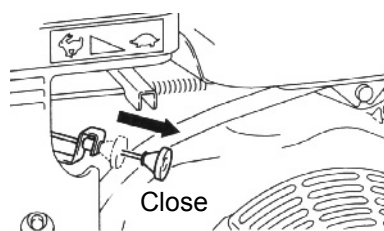

Operation

4. Close the choke.

- * If the engine is warm or at high ambient temperatures, open the choke approximately half way or fully.
- * If the engine is cold or at low ambient temperatures, close the choke.

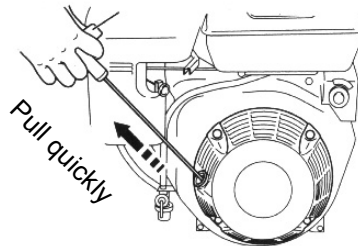

5. Recoil starter

- * Slowly pull the recoil starter handle until you can feel resistance (compression stroke). Return the recoil starter handle to its original position and pull with force. Do not pull out the entire length of the rope.
- * As soon as the engine has started, rewind the starter rope by slowly returning the recoil starter handle to its original position.

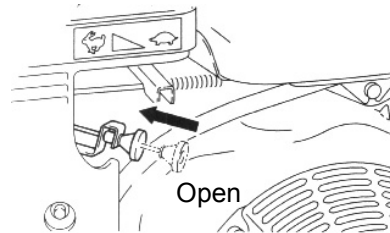

6. Choke

- * After the engine has been started, slowly open the choke and then leave it in the fully open position.
- * If the engine is cold or at low ambient temperatures, never fully open the choke immediately after the engine has been started or the engine will stall.

6.11 Engine operation

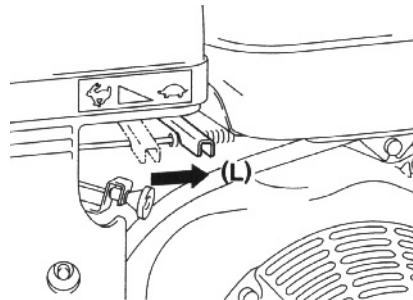

After the engine has started, shift the throttle lever to low (L) engine speed and allow the engine to warm up for a few minutes.

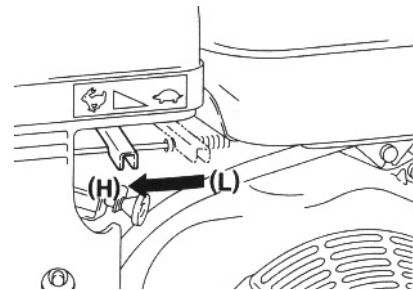

Slowly shift the throttle lever towards the (H) position for high engine speed in order to set the required engine speed.

Note: If no high engine speed is required, shift the throttle lever back to operate the engine at idle speed in order to save fuel and extend the service life of the engine.

Operation

6.12 Switch off the engine

6.12.1 To turn off the engine in the event of an emergency, switch the main switch (1) to "0". Under normal circumstances, proceed as follows:

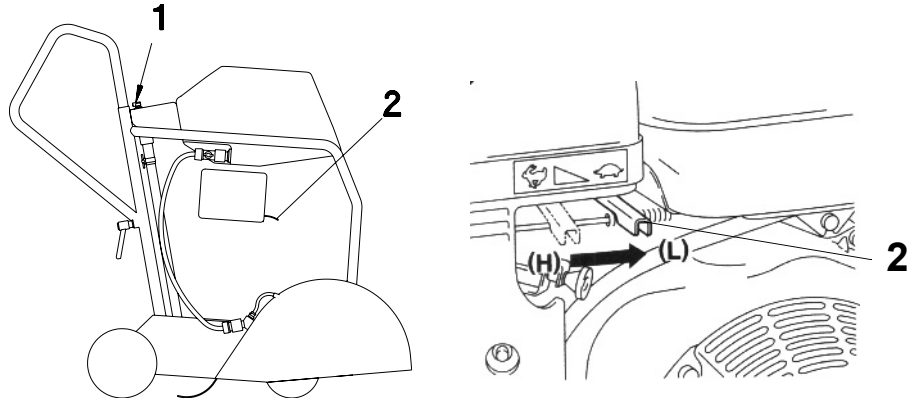

1. Shift the throttle lever (2) to the (L) position for low engine speed and allow the engine to operate at idle speed for a short time before switching it off.
2. Switch the main switch (1) to "0".

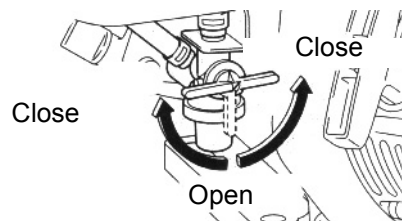

3. Close the fuel tap.

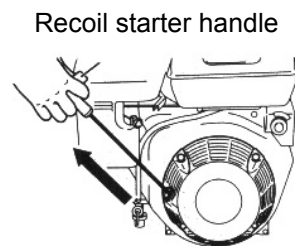

4. Slowly pull the recoil starter handle until you feel resistance and then return the recoil starter handle to its original position.

Note: This procedure is necessary in order to prevent humid ambient air from entering the combustion chamber.

6.12.2 Switching off the engine via the fuel tap

Close the fuel tap and wait until the engine stalls. Never leave fuel in the carburetor over a long period of time while the engine is switched off. Otherwise, the fuel channels in the carburetor become blocked by dirt which results in faulty operation.

7. Maintenance

7.1 Maintenance schedule

Component	Maintenance work	Maintenance interval
Machine	Check for signs of damage and wear – change, if necessary the components.	Before operation
Safety devices		
Main switch		
Air cleaner	<ul style="list-style-type: none"> - Check for external damage and a tight fit. - Check foam and filter element – clean or replace, if necessary. 	8 hours (daily)
Fuel	<ul style="list-style-type: none"> - Check the tank cap for leakage – change, if necessary. - Check the fuel level – add oil as needed. 	
Drive motor	Monitoring of: <ul style="list-style-type: none"> - Excessive vibrations, operating noise. - Engine oil and fuel leaks. 	
Engine oil	Check the oil level – add oil as needed.	
Miscellaneous	<ul style="list-style-type: none"> - Check the cutting blade for damage and tightness – replace or tighten, if necessary. - Check the direction of rotation arrow of the cutting blade. - Check that the height adjustment moves freely. - Check the water supply. 	
Engine oil	Initial oil change.	20 hours
Air cleaner	Clean – change, if necessary.	50 hours (weekly)
Belt	Check tension and wear – change, if necessary.	
Spark plug	Clean, set electrode gap 0.7-0.8 mm.	
Engine oil	Change.	
Fuel filter	Have this replaced by Wacker Neuson service.	200 hours
Spark plug	Change.	300 hours (annually)
Valve clearance	Have this repaired by Wacker Neuson service.	

Maintenance

7.2 Checking engine oil level

- * Switch off the engine.
- * Align the engine bolting level horizontally.
- * Remove any dirt around the oil level dipstick.
- * Remove the oil level dipstick and wipe it with a clean, lint-free cloth.
- * Screw the oil level dipstick all the way back in and pull it out again.
- * Check: The motor oil level must be between the lower and upper marks.
- * If necessary, pour new engine oil into the opening until the upper mark is reached on the oil level dipstick (see chapter *Technical data* for oil type).
- * Screw in the oil level dipstick and tighten it by hand.

7.3 Changing the engine oil

The work area should be covered with a waterproof sheet to protect the floor (protection of the environment).

- * Align the engine bolting level horizontally.
- * Bring the engine to a hand warm temperature, either by letting it cool down or running it until it is warm.
- * Switch off the engine.
- * Place a sufficiently large container under the oil drain hose to catch the used oil.
- * Remove oil drain hose from the holder.
- * Remove any dirt around the locking screw.
- * Unscrew the cap nut.
- * Let the used oil drain out completely.

Avoid spilling oil. Remove any spilled oil immediately.

- * Close oil drain hose with cap nut.
- * Attach oil drain hose to the holder.
- * Pour new engine oil (see chapter *Technical data*) into the opening of the oil level dipstick until the upper mark is reached on the oil level dipstick (see *Checking engine oil level*).
- * Screw in the oil level dipstick and tighten it by hand.

Dispose of the used oil in accordance with the applicable regulations.

7.4 Cleaning the air cleaner

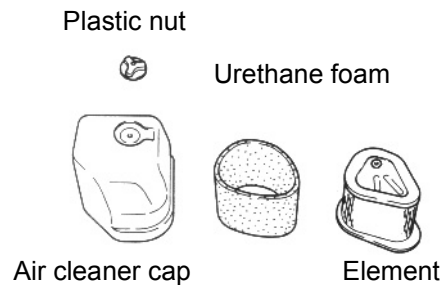

A dirty air cleaner causes starting difficulties, a drop in power, engine faults and considerably reduces the service life of the engine. Always keep the air cleaner cartridge clean.

Therefore, the air cleaner cartridge has to be cleaned regularly. During the installation, the paper element and the polyurethane foam must be placed on the bottom part. Make sure that the nozzle has been installed and then tighten the filter cover with the plastic nut.

Cleaning the urethane foam:

Clean the filter element in a detergent solution and then allow it to completely dry.

Clean the urethane foam filter element every 50 hours.

Paper element:

Clean the paper element by knocking it gently. Never use oil.

If the engine is operated in extremely dusty areas, the air cleaner elements must be cleaned and replaced more often.

7.5 Cleaning the screws, nuts and bolts

Retighten loose screws and nuts. Check for fuel and oil leaks. Always ensure optimum operating safety.

Maintenance

7.6 Tightening the belt

Check the belt in the course of the weekly engine maintenance and re-tighten it as follows, if necessary:

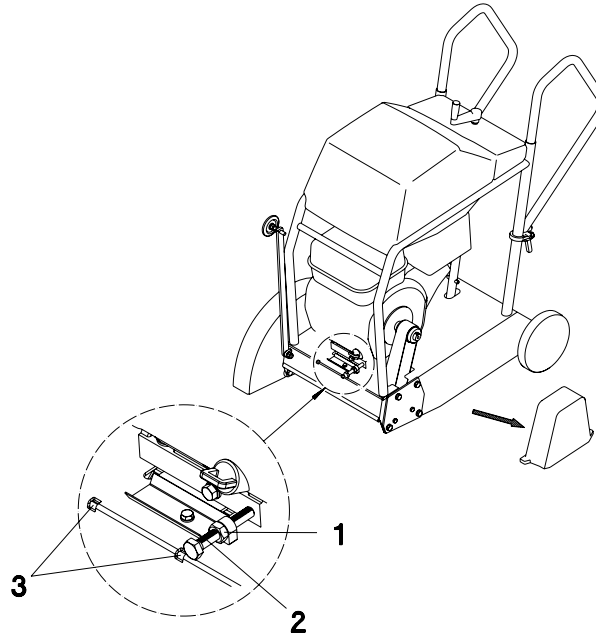

1. Remove the belt guard.
2. Loosen the jam nut (1).
3. Loosen the four fastening nuts of the engine until the engine can be moved without play.
4. Tighten the belt with the tension screw (2).
V-belt tension 700 N (vibration frequency 98 Hz).
5. If necessary, correct the parallel alignment of the engine.
As a first step, tighten a fastening nut of the engine and correct the alignment by means of the tension screw (2).
6. Tighten all fastening nuts of the engine as well as the jam nut (1).
7. Mount the belt guard.

Note: The frame is provided with two recesses (3) which can be used to measure the parallel alignment of the engine.

7.7 Changing the belt

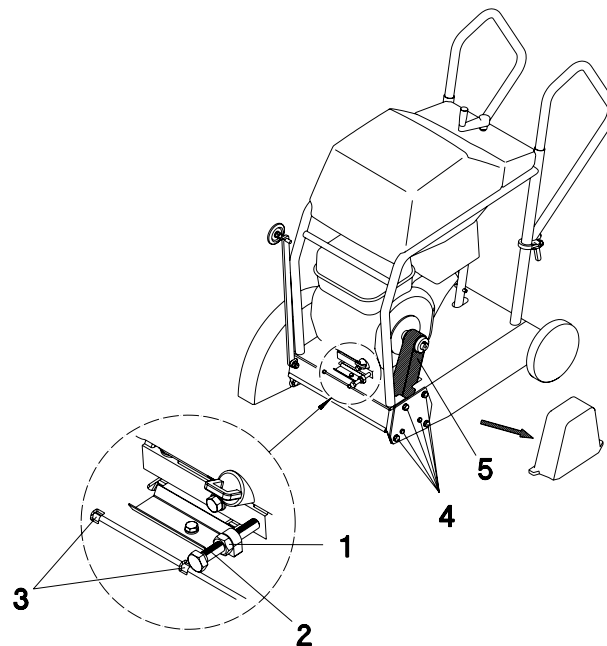

1. Remove the belt guard.
2. Loosen the jam nut (1).
3. Loosen the four fastening nuts of the engine until the engine can be moved without play.
4. Unscrew the bearing flange (6 screws - (4)).
5. Replace the belt (5).
6. Screw on the bearing flange (6 screws - (4)).
7. Tighten the belt with the tension screw (2).
V-belt tension 700 N (vibration frequency 98 Hz).
8. If necessary, correct the parallel alignment of the engine.
As a first step, tighten a fastening nut of the engine and correct the alignment by means of the tension screw (2).
9. Tighten all fastening nuts of the engine as well as the jam nut (1).
10. Mount the belt guard.

Note: The frame is provided with two recesses (3) which can be used to measure the parallel alignment of the engine.

Maintenance

7.8 Checking the spark plug

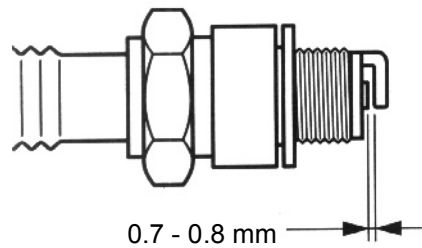

- * Remove any soot deposits from the electrodes of the spark plug using a spark plug cleaner or a wire brush.
- * Check the spark plug gap and set it to 0.7 - 0.8 mm, if necessary.
- * Select the correct spark plug, see chapter *Technical Data*.

8. Signs

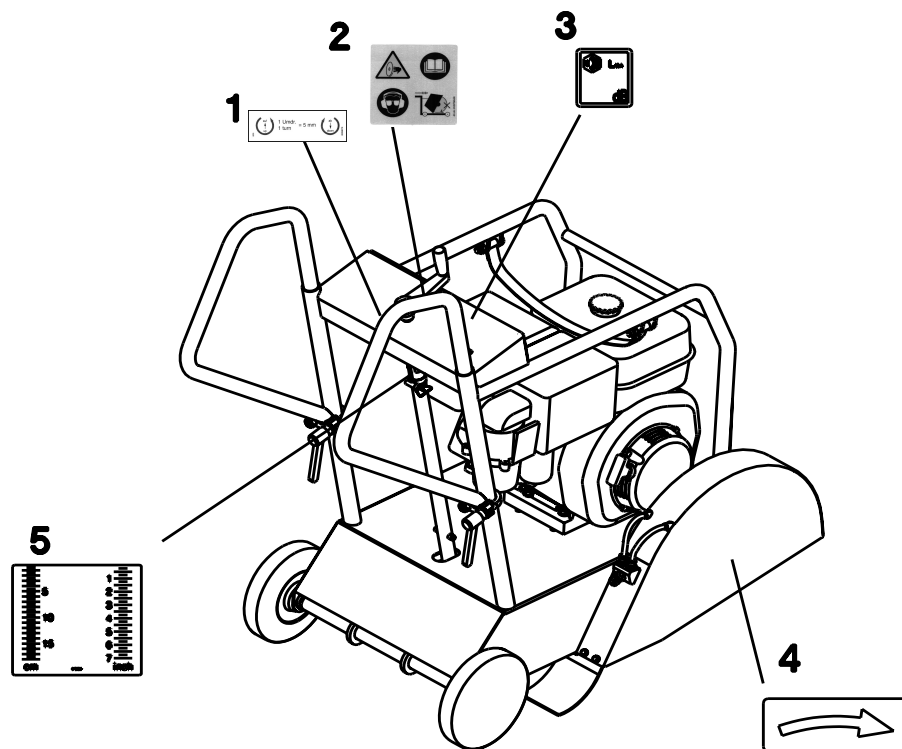

1	Cutting depth setting
2	Note <ul style="list-style-type: none"> - Caution, risk of injury - Read the operator's manual. - Wear a helmet, eye protection and ear protection! - Machine may not be offset with the cutting blade rotating.
3	Sound power level
4	Rotational direction arrow
5	Depth of cut indicator



EC Declaration of Conformity

Manufacturer

Wacker Construction Equipment AG
Preußenstraße 41
D-80809 München

Product

Type		BFS 1345 AB	BFS 1345 AB Z	BFS 1345 B	BFS 1345 BZ
Product type		Floor saw			
Item number		0008764 0610141	0610242	0008909 0610142	0610243
Installed power output	[kW]	9.6		9.9	
Measured sound power level	dB(A)	106			
Guaranteed sound power level	dB(A)	107			

Conformity assessment procedure acc. to 2000/14/EC, Appendix V.

Guidelines and standards

This is to certify that this product meets and complies with the relevant regulations and requirements of the following guidelines and standards:

98/37/EC, 2000/14/EC, 2005/88/EC, 2004/108/EC, EN 55012:2007

Munich, October 2008

Franz Beierlein
Head of product management

Dr. Michael Fischer
Head of Research and Development

VDE Prüf- und Zertifizierungsinstitut

VDE VERBAND DER ELEKTROTECHNIK
ELEKTRONIK INFORMATIONSTECHNIK e.V.

CERTIFICATE

Registration-Number: 6236/QM/06.97

This is to certify that the company

WACKER



**Wacker Construction Equipment AG
Wacker-Werke GmbH & Co. KG**

at the following locations

**Head Office Munich
Preußenstraße 41
80809 Munich**

**Production plant Reichertshofen
Karlsfeld logistics centre
Sales regions with all branches all over Germany**

has implemented and maintains a
Quality Management System for the following scope:

**Machine manufacture
Construction machines**

This Q System complies with the requirements of

DIN EN ISO 9001:2000

and the requirements of the German and international Road Traffic Act.

This Certificate is valid until 2009-06-05.

VDE Testing and Certification Institute
Certification

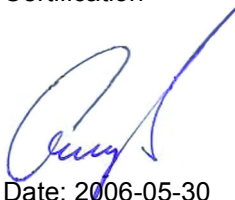

Date: 2006-05-30

63069 Offenbach, Merianstraße 28
Telefon: +49 (0) 69 83 06-0, Telefax: +49 (0) 69 83 06-555
E-Mail: vde-institut@vde.com, <http://www.vde-institut.com>



The VDE Testing and Certification Institute is accredited by DAR Accreditation
Bodies according to DIN EN ISO 17020 and DIN EN ISO 45012 and notified in the EU
under ID.No. 0366.

TGA-ZM-09-92-00
KBA-ZM-A 00021-97

