



CP 9 & CP 9S Handrill

**SPARES
LIST**

**& MAINTENANCE
INSTRUCTIONS**



CP9 & CP9S Handrill Model "B-L" General Arrangement

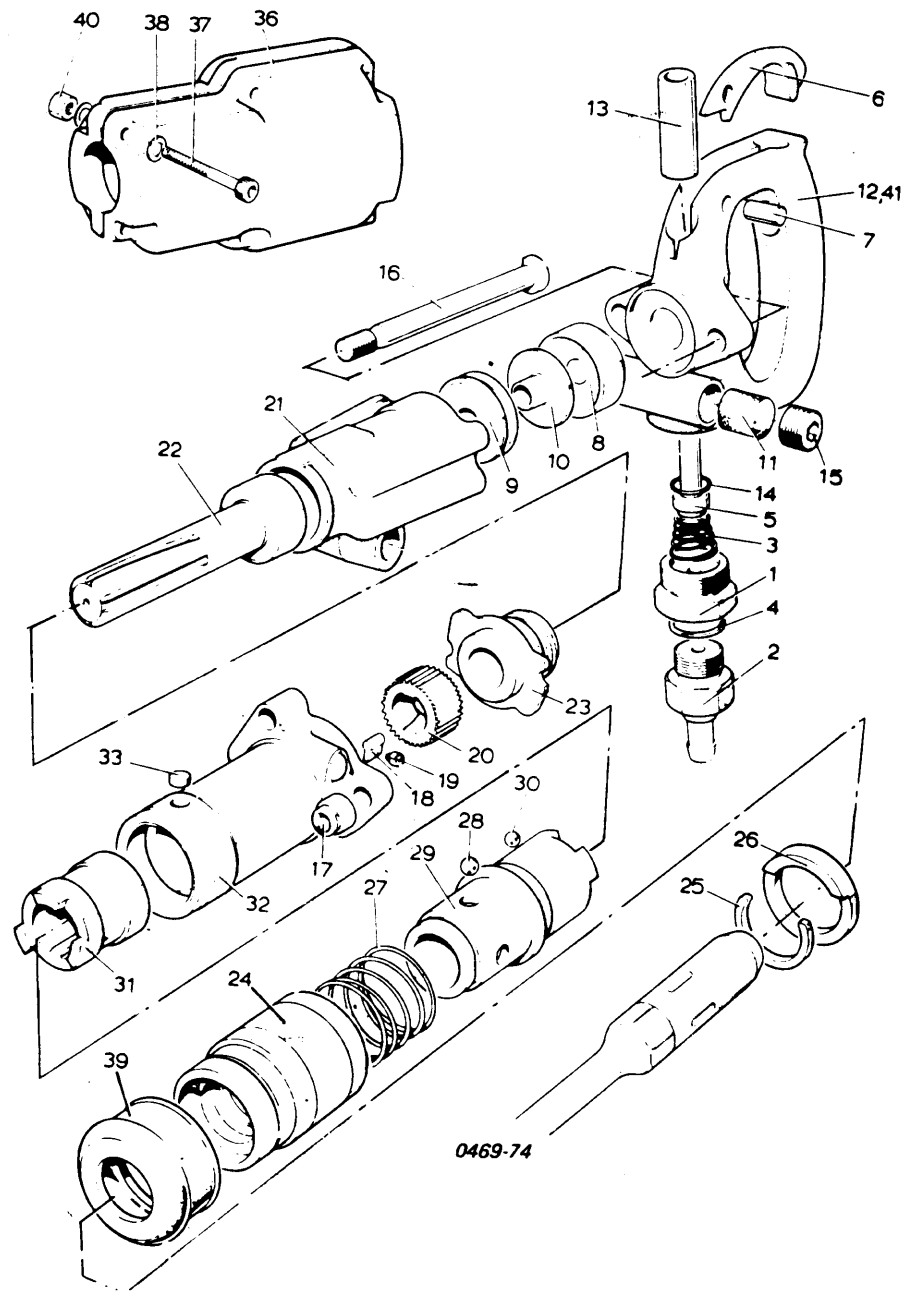

0469-74

CP9 & CP9S Handrill Model "B-L" Parts List

Item No.	Part No.	Description	No. Reqd.
1	F-064697	Air Inlet Bushing	1
2	F-064695	Hose Tail	1
3	R-085596	Throttle Valve Spring	1
4	F-064696	Gasket	1
5	R-086329	Throttle Valve	1
6	F-027853	Throttle Lever	1
7	R-075404	Throttle Lever Pin	1
8	R-085896	Rear Valve Seat	1
9	R-085898	Front Valve Seat	1
10	R-085897	Valve	1
11	R-085895	Oil Chamber Felt	1
12	F-034495	Handle (Includes Nos. 13 & 14)	1
13	R-085599	Bush	1
14	R-086098	'O' Ring (Special)	1
15	C-077941	Oil Plug	1
16	F-034249	Through Bolt	2
17	S-013073	Through Bolt Nut	2
18	F-034066	Pawl	2
19	F-085890	Pawl Spring	2
20	F-816123	Ratchet Ring	1
21	F-085886	Cylinder	1
22	F-816122	Piston	1
23	R-085887	Cylinder Bushing	1
24	F-827148	Retainer Sleeve (Includes No. 39)	1
25	F-826893	Retainer Ring	1
26	F-826683	Retainer Plate	1
27	R-086605	Retainer Sleeve Spring	1
28	F-035621	Steel Retainer Ball	4
29	F-826892	Chuck	1
30	S-013112	Chuck Retainer Ball	17
31	R-085900	Chuck Sleeve	1
32	R-136592	Fronthead	1
33	F-061888	Ball Retainer Plug	1
36*	F-826972	Muffler (Includes Index Nos. 37,38, & 40)	1
37*	F-826973	Cap Screw	6
38*	F-826979	Washer	12
39	F-815343	Dust Excluder	1
40*	C-037118	Nut	6
41	F-034496	Handle Complete	1
		(Consists of 1 of Index Nos 1,3,5,6,7,11,12&15)	
	F-826924	Service Kit(not shown)	
		Consists of Items 25 & 28)	

Items marked thus * are applicable to CP9S only.

Unique Parts for CP9 and CP9S Hex Chuck

27	F-816162	Retainer Sleeve Spring
29	F-816159	Chuck

CP9 & CP9S

Handrill

General Instructions

Air Supply

To enable the drill to function satisfactorily, it is essential that a constant 80-90 p.s.i. pressure of clean, dry air is supplied to the air inlet bushing. Air piping should be a minimum of 3/8" hose size or larger, used with couplings of a minimum 9/32" I.D. The installation of an air line separator and filter to purify and dry the air supply and a regulator to eliminate any pressure fluctuations are recommended. These control units should be located as near to the tool as operation will allow.

Operating Cautions

Always operate drill with a drill rod or steel fitted and with the tool held down to the work, thus avoiding damage which would be caused by allowing the piston to strike against the face of the cylinder bushing.

Always wear approved eye protection and safety type shoes to avoid personal injury

Preparing for Operation

Prior to the initial operation of the drill disconnect the air hose and pour approximately one teaspoonful of recommended oil into the tool air inlet. Blow out the air line to remove any accumulations of dirt and condensation before connecting the tool. Connect the air line and operate the tool to allow the oil to be carried through the moving parts of the tool.

Lubrication

Daily, prior to operating the drill the 'Preparation for Operation' sequence should be carried out. Daily before using and after each four hours of service fill the oil reservoir with recommended oil. See 'Recommended Lubricants'. An air line lubricator should be installed in the air line system. This will introduce a fine oil spray to the compressed air flow and thence to the moving parts of the tool. The amount of oil supplied is adjustable thus preventing too much lubrication. Use of this lubricator will ensure a constant and adequate supply of oil. Indications of proper lubrication are the presence of an oil mist in the exhaust air and slight traces of oil on drill or adaptor shank. If these are not apparent, check oil reservoir, replace oil chamber felt, if dirty, and ensure that the port leading from the oil chamber to the air passage is unobstructed.

Loss of Power or Erratic Action

Drill failure, loss of power or erratic action may be caused by external factors. The following checks should be made:-

1. Check the compressed air pressure — a constant air pressure of 80-90 p.s.i. is required at the tool to maintain the rated performance. A drop in air pressure may be caused by lowered compressor output, excessive drain on the air line or by using either a hose or connections of improper size and condition.
2. Check for impure air — wet air tends to wash the lubricant from the cylinder resulting in general rusting and corroding. Dirt in the air supply will impede valve action and cause damage to the tool.

If these two checks prove negative:-

1. Check drill lubrication— disconnect the tool and pour a liberal quantity of recommended oil diluted with an equal amount of paraffin into the tool air inlet. Operate the tool to flush out any condensate or dirt.

CP9 & CP9S

Handrill

General Instructions

Maintenance Recommendations.

2. Check all mechanical parts — disassemble the tool and thoroughly clean and inspect all parts. Replace worn or broken parts, relubricate and reassemble tool.

Economic operation can only be achieved if the drill is in perfect running condition. A regularly scheduled inspection period programme should be adhered to. The correction of minor faults will prevent extensive repairs at a later date and maintain the tool at its highest efficiency.

1. The drill should be adequately lubricated. Ensure that the oiler is always kept saturated with recommended oil.
2. Provide a constant pressure of 80-90p.s.i. of clean, dry air to enable the drill to operate efficiently.
3. The air line system should always be composed of hose and couplings of proper dimension and condition.
4. Establish and maintain an inspection and repair programme scheduled at frequent, regular intervals.

Spare Parts

All replacement and spare parts should be ordered through C.P. Equipment Local Dealer. When requesting these items please state Tool Name, Size, Model Letter and Serial Number in addition to the individual Part Number and Description of the parts.

Disassembly & Assembly Cautions

The CP9 drill is constructed with precision built components designed to operate at close clearances and in perfect alignment. Ensure that no parts are scored, burred or distorted during assembly.

Be sure straight spline on piston (22) engages straight spline on chuck sleeve (31) and that spiral spline on piston engages spiral spline of ratchet ring.

Assemble Ratchet ring (20) in fronthead (32) so that short flats of ratchet teeth engage ends of Pawls (18).

If burrs are raised around four ball slots in shank of drill steel, file down smooth to permit easy entry and removal of drill steel and efficient operation of the chuck.

Tighten through bolt nuts (17) evenly to prevent binding. After tightening, rotate chuck by hand to make sure rotation is free.

Disassembly—Front Head & Cylinder

Remove the retainer ring (25) and retainer plate (26) from the chuck (29) thus permitting the removal of the retainer sleeve (24) and the retainer sleeve spring (27). Check the retainer ring (25), ball bush (34), plate (26) and steel retainer balls (28) for wear and replace where necessary. Extract the ball retainer plug (33) from the fronthead (32) and remove the chuck retainer balls (30). Slip the chuck (29) and chuck sleeve (31) from the fronthead (32).

Unscrew the through bolt nuts (17) and remove the through bolts (16) and lay handle assembly aside.

Detach the fronthead (32) and slip out the ratchet ring (20); Examine this ring for wear and replace if necessary. Remove the pawls (18) and pawlsprings (19). Again, examine the pawls and

CP9 & CP9S Handrill General Instructions

springs for signs of wear and replace if necessary.

Remove the cylinder bushing (23) from the cylinder (21) thus releasing the piston (22). Inspect the cylinder and piston for signs of wear and renew if necessary. The rear valve seat (8), valve (10) and front valve seat (9) can be removed and inspected for wear and renewed if necessary.

Disassembly – Handle

Knock out the throttle lever pin (7) from the handle (12) and extract the throttle lever (6).

Unscrew the hose tail (2) for inspection of gasket (4). Unscrew the air inlet bushing (1) and remove the throttle valve spring (3) throttle valve (5) and 'O' ring (14).

For examination of the oil chamber felt (11), remove the oil plug (15).

For assembly of the CP9 reverse the disassembly instructions.

CP9 & CP9S HAND DRILL Recommended Lubricants

Manufacturer	Lubricant
CP	Airolene Tool Oil
Esso	Nuto H 40
Gulf	Harmony 41 AW
Mobiloil	Velocite NO. 10
Dalton	P101/P
Shell	Tellus 23
Burmah Castrol	Hyspin AWS 22
BP Power Petroleum	BP Energol CS40
Duckham	Zeroflo 4
Sternol	Albatross 21
Petrofina	Hydran 31
Chevron	Vistac Oil 9X
Century Oil	P313