

0215449en	001
03.2008	

Modular internal vibrator

HMS

M1000, M2000, M3000



Operator's manual

1	Foreword	5
2	Introduction	6
	2.1 Means of representation for this operator's manual	6
	2.2 WACKER representative	7
	2.3 Described machine parts	7
3	Safety information	8
	3.1 Principle	8
	3.2 Qualification of the operating personnel	11
	3.3 Protective gear	11
	3.4 Transport	12
	3.5 Operating safety	12
	3.6 Safety during the operation of electric appliances	13
	3.7 Maintenance	15
	3.8 Safety labels	15
4	Scope of delivery	16
5	Description	17
	5.1 Application	17
	5.2 Functionality	17
	5.3 Drive components and operator's controls	18
	5.4 Flexible shaft components	19
	5.5 Vibrator head components	19
6	Transport	20
7	Operation	21
	7.1 Prior to starting the machine	21
	7.2 Mounting the vibrator head	22
	7.3 Starting up	24
	7.4 Decommissioning	26
8	Maintenance	28
	8.1 Maintenance schedule	29
	8.2 Maintenance work	30
9	Troubleshooting	39
10	Disposal	40
	10.1 Disposal of the machine	40

11 Accessories 41

 11.1 Special wrench for flexible shaft 41

 11.2 Pipe thread seal 41

 11.3 Special lubricant for flexible shafts 41

 11.4 SS-adapter 41

 11.5 Carrying belt 41

12 Technical data 42

 12.1 Drive 42

 12.2 Noise and vibration figures 43

 12.3 Flexible shafts 44

 12.4 Vibrator head 45

 12.5 Notes regarding class rating and protection class 46

 12.6 Extension cable 47

 12.7 Allowable Drive - Flexible Shaft - Vibrator Head combinations 49

EC Declaration of Conformity 51

UL Certificate 53

DIN EN ISO 9001 Certificate 55

1 Foreword

This operator's manual contains information and procedures for the safe operation and maintenance of your WACKER machine. In the interest of your own safety and to prevent accidents, you should carefully read through the safety information, familiarize yourself with it and observe it at all times.

This operator's manual is not a manual for extensive maintenance and repair work. Such work should be carried out by WACKER Service or authorized specialists.

The safety of the operator was one of the most important aspects taken into consideration when this machine was designed. Nevertheless, improper use or incorrect maintenance can pose a risk. Please operate and maintain your WACKER machine in accordance with the instructions in this operator's manual. Your reward will be troublefree operation and a high degree of availability.

Defective machine parts must be replaced immediately!

Please contact your WACKER representative if you have any questions concerning operation or maintenance.

All rights reserved, especially reproduction and distribution rights.

Copyright 2008 Wacker Construction Equipment AG

No part of this publication may be reproduced in any form or by any means, electronic or mechanical, including photocopying, without the expressed written permission of WACKER.

Any type of reproduction, distribution or storage on data media of any type and form not authorized by WACKER represents an infringement of copyright and will be prosecuted.

We expressly reserve the right to make technical modifications – even without special notice – which aim at further improving our machines or their safety standards.

2 Introduction

2.1 Means of representation for this operator's manual

Warning symbols

This operator's manual contains safety information of the categories: DANGER, WARNING, CAUTION, NOTICE.

They should be followed to prevent danger to life and limb or damage to equipment or improper service.



DANGER

This warning notice indicates hazards that result in serious injury or even death.

- ▶ Danger can be avoided by the following the actions mentioned.
-



WARNING

This warning notice indicates hazards that can result in serious injury or even death.

- ▶ Danger can be avoided by the following the actions mentioned.
-



CAUTION

This warning notice indicates hazards that can result in minor injury.

- ▶ Danger can be avoided by the following the actions mentioned.
-

NOTICE

This warning notice indicates hazards that can result in material damage.

- ▶ Danger can be avoided by the following the actions mentioned.
-

Notes

Note: Complementary information will be displayed here.

Instructions

- ▶ This symbol indicates there is something for you to do.
1. Numbered instructions indicate that you have to carry out something in a defined sequence.
- This symbol is used for lists.

2.2 WACKER representative

Depending on your country, your WACKER representative is your WACKER Service, your WACKER affiliate or your WACKER dealer.

You can find the addresses in the Internet at www.wackergroup.com.

The addresses of the WACKER main locations are located at the end of this operator's manual.

2.3 Described machine parts

This operator's manual is valid for different machine parts from a product range. Therefore some figures can differ from the actual appearance of your machine. It is also possible that the descriptions include components which are not a part of your machine.

Details for the described machine types can be found in the chapter *Technical Data*.

3 Safety information

3.1 Principle

State of the art

This machine has been constructed with state-of-the-art technology according to the recognized rules of safety. Nevertheless, when used improperly, dangers to the life and limb of the operator or to third persons or damage to the machine or other materials cannot be excluded.

Proper use

The machine may only be used for compacting fresh concrete. The vibrator head has to be immersed in the fresh concrete.

Its proper use also includes the observance of all instructions contained in this operator's manual as well as complying with the required service and maintenance instructions.

Any other use is regarded as improper. Any damage resulting from improper use will void the warranty and the liability on behalf of the manufacturer. The operator assumes full responsibility.

Structural modifications

Never attempt to modify the machine without the written permission of the manufacturer. To do so will endanger your safety and the safety of other people! In addition, this will void the warranty and the liability on behalf of the manufacturer.

Especially the following are cases of structural modifications:

- Opening the machine and the permanent removal of components from WACKER.
- Installing new components which are not from WACKER and not equivalent to the original parts in design and quality.
- Installation of accessories which are not from WACKER.

It is no problem to install spare parts from WACKER.

It is no problem to install accessories that are available in the WACKER product range of your machine. Please refer to the installation regulations in this operator's manual.

Requirements for operation

The ability to operate the machine safely requires:

- Proper transport, storage and setup.
- Careful operation.
- Careful service and maintenance.

Operation

Operate the machine only as intended and only when in proper working condition.

Operate the machine in a safety-conscious manner with all safety devices attached and enabled. Do not modify or disable any safety devices.

Before starting operation, check that all control and safety devices are functioning properly.

Never operate the machine in a potentially explosive environment.

Supervision

Never leave the machine running unattended!

Maintenance

Regular maintenance is required in order for the machine to operate properly and reliably over time. Neglected maintenance work can make the machine dangerous to use.

- Strictly observe the prescribed maintenance intervals.
- Do not use the machine if it requires maintenance or repairs.

Malfunctions

If you detect a malfunction, you must shut down and secure the machine immediately.

Eliminate the malfunctions that impair safety immediately!

Have damaged or defective components replaced immediately!

For further information, refer to chapter *Troubleshooting*.

Spare parts, accessories

Only use spare parts and accessories from WACKER. Non-compliance will exempt the manufacturer from all liability.

Exclusion of liability

WACKER will refuse to accept liability for injuries to persons or for damage to materials in the following cases:

- Structural modifications.
- Improper use.
- Improper handling.
- Use of spare parts and accessories not produced by WACKER.

Operator's manual

Always keep the operator's manual near the machine or near the worksite for quick reference.

If you have misplaced the operator's manual or require an additional copy, contact your WACKER representative or download it from the Internet (www.wackergroup.com).

Always hand over this operator's manual to other operators or to the future owner of the machine.

Country-specific regulations

Observe the country-specific regulations, standards and guidelines in reference to accident prevention and environmental safety, for example those pertaining to hazardous materials and wearing protective gear.

Complement the operator's manual with additional instructions taking into account the operational, regulatory, national or generally applicable safety guidelines.

Operator's controls

Always keep the operator's controls of the machine dry, clean and free of oil or grease.

The function of the operator's controls must not be manipulated or rendered ineffective.

Cleaning

Always keep the machine clean and be sure to clean it each time you have finished using it.

Do not use gasoline or solvents. Danger of explosion!

Checking for signs of damage

Inspect the machine when it is switched off for any signs of damage at least once per work shift.

Do not start the machine if there is visible damage or defects.

Have any damage or defects eliminated immediately.

3.2 Qualification of the operating personnel

Operator qualifications

Only trained personnel are permitted to start and operate the machine. The following rules also apply:

- You are physically and mentally fit.
- You have received instruction on how to independently use the machine.
- You have received instruction in the proper use of the machine.
- You are familiar with required safety devices.
- You are authorized to start machines and systems in accordance with the standards governing safety.
- You have been assigned to work on the machine by your company.

Incorrect operation

Incorrect operation or misuse by untrained personnel can endanger the health and safety of the operator and also cause machine and material damage.

Operating company responsibilities

The operating company must make the operator's manual available to the operator and ensure that the operator has read and understood it.

Work recommendations

Please observe the recommendations below:

- Work only if you are in a good physical condition.
- Work attentively, particularly as you finish.
- Do not operate the machine when you are tired.
- Carry out all work calmly, circumspectly and carefully.
- Never operate the machine under the influence of alcohol, drugs or medication. This can impair your vision, reactions and your judgment.
- Work in a manner that does not endanger others.

3.3 Protective gear

Work clothing

Clothing should be appropriate, i.e. should be close-fitting but not restrict your movement.

When on construction sites, do not wear long hair loosely, loose clothing or jewelry including rings. These objects can easily get caught or be drawn in by moving machine parts.

Personal protective gear

Wear personal protective gear to avoid injuries or health hazards:

- Non-skid, hard-toed shoes.
- Work gloves made of durable material.
- Overalls made of durable material.
- Hard hat.
- Ear protection.

Ear protection

This machine generates noise that exceeds the country-specific permissible noise levels (individual rating level). It may therefore be necessary to wear ear protection. You can find the exact value in the chapter *Technical Data*.

WACKER recommends that you always wear ear protection.

3.4 Transport**Switching off the machine**

Before you transport the machine, switch it off and pull the plug out of the plug receptacle. Allow the motor to cool down.

Transporting the machine

Secure the machine on the transport device against tilting, falling or slipping.

Restarting

Machines, machine parts, accessories or tools that were detached for transport purposes must be re-mounted and fastened before restarting.

Only operate in accordance with the operating instructions.

3.5 Operating safety**Work environment**

Familiarize yourself with your work environment before you start work. This includes e.g. the following items:

- Obstacles in the work and traffic area.
- Load-carrying capacity of the ground.
- The measures needed to cordon off the construction site from public traffic.
- The measures needed to secure walls and ceilings.
- Options available in the event of an accident.

Starting the machine

Observe the safety information and warning notices located on the machine.

Never attempt to switch on a machine that requires maintenance or repairs.

Switch on the machine as directed in the operator's manual.

Vertical stability

Always make sure that you stand firmly when working with the machine. This applies particularly when working on scaffoldings, ladders, etc.

Switching off the machine

Switch off the machine and pull the plug out of the plug receptacle in the following situations:

- Before breaks.
- If you are not using the machine.

Store the machine or put it down in such a way that it cannot tilt, fall down or slip.

Storage

Store the machine or put it down in such a way that it cannot tilt, fall down or slip.

Storage location

Store the machine after operation at a sealed off, clean and dry location inaccessible to children.

3.6 Safety during the operation of electric appliances**Specific regulations for electrical appliances**

Observe the safety information provided in the brochure *General Safety Rules* which is included in the scope of delivery of your machine.

Also observe the country-specific regulations, standards and guidelines in reference to accident prevention in connection with electrical equipment and machines.

Power supply with residual current protective device (> 50 V AC)

Note: The rated voltage is indicated on the nameplate of your machine.

The machine can be connected to a 15 A/16 A/20 A shock-proof plug receptacle (continental type) with a corresponding overload protection.

One of the following fault current protective switches is required:

- Standard fault current protective switch (AC sensitive, type A).
- AC/DC sensitive fault current protective switch (type B).

The machine may only be connected to an electric power supply with all machine parts in proper working condition. Take special notice of the following machine parts:

- Plug.
- Power cable over the entire length.

The machine may only be connected to an electric power supply whereby the connector of the grounded conductor (PE) is intact.

There must be at least one of the following safety devices if connected to a stationary or mobile generator:

- Fault current protective switch.
- Isolation (earth leakage) monitor.
- IT-net.

Note: Observe the respective national safety regulations!

Extension cable

The machine may only be operated with undamaged extension cables!

Only use extension cables with grounded conductor and correct connection of the grounded conductor to the plug and coupling (not for 42 V machines).

Only use extension cables which are suitable for use at construction sites: Average rubber hose H05RR-F or better – WACKER recommends H07RN-F or a country-specific equivalent design.

Immediately replace damaged extension cables (e.g. tears in the sheathing) or loose plugs and couplings.

Protecting the power cable

Do not use the power cable to pull or lift the machine.

Do not unplug the power cable by pulling on the cable.

Protect the power cable from heat, oil and sharp edges.

If the power cable is damaged or the plug is loose, have it replaced immediately by your WACKER representative.

3.7 Maintenance

Maintenance work

Service and maintenance work must only be carried out to the extent described in these operating instructions. All additional work, e.g., the replacement of the power cable, must be carried out by the WACKER representative to prevent any safety risks.

For further information, refer to chapter *Maintenance*.

Disconnecting the machine from the electric power supply

Before carrying out service or maintenance work, pull the plug out of the plug receptacle in order to disconnect the machine from the electric power supply.

3.8 Safety labels

Your machine has adhesive labels containing the most important instructions and safety information.

- Make sure that all the labels are kept legible.
- Replace any missing or illegible labels.

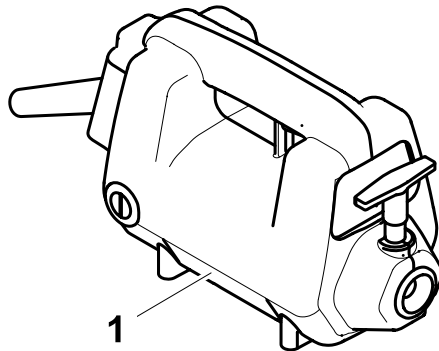

Item	Label	Description
1		<p>WARNING Read operator's manual to reduce risk of injury. Wear ear protection. Keep in operative position.</p>

4 Scope of delivery

Individual components of the machine must be ordered separately.

The total scope of delivery includes:

- Drive.
- Flexible shaft.
- Vibrator head.
- Operator's manual.
- Parts book.
- General safety instructions.

5 Description

5.1 Application

The machine is designed to compact fresh concrete in formworks and on even surfaces.

The vibrator head has to be immersed in the fresh concrete.

5.2 Functionality

Principle

The machine consists of the following components:

- Drive.
- Flexible shaft.
- Vibrator head.

You can combine these components in various designs depending upon the conditions of use.

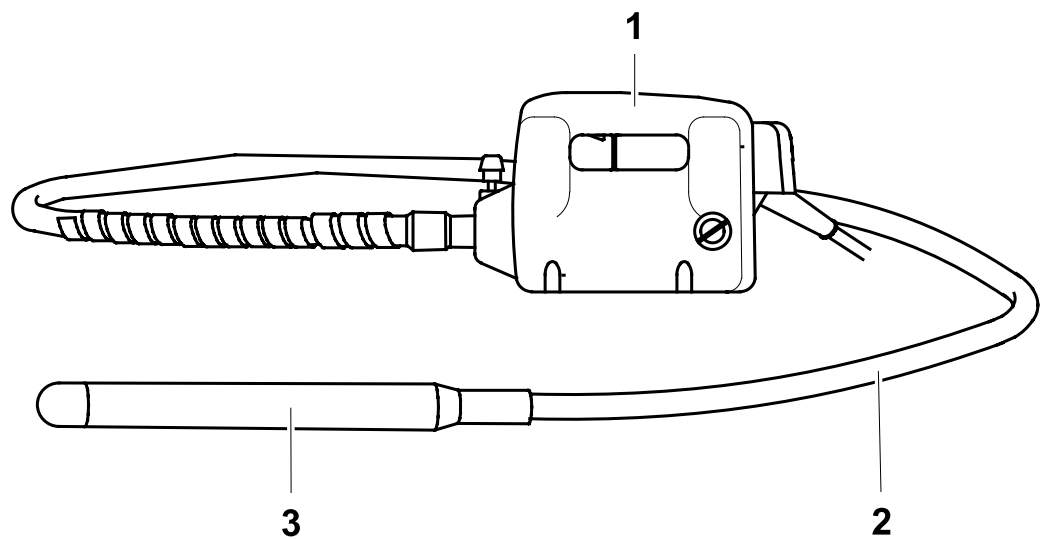

Item	Designation	Item	Designation
1	Drive	3	Vibrator head
2	Flexible shaft		

By means of the flexible shaft, the drive drives the vibrator head, which generates high-frequency vibrations. These vibrations will cause the vibrator head to execute precessions.

Concrete is deaerated and compressed in the effective range of the vibrator head when the vibrator head is immersed into the fresh concrete.

The fresh concrete is simultaneously cooling the vibrator head.

Note: The concrete is being compressed for as long as bubbles of air arise.

5.3 Drive components and operator's controls

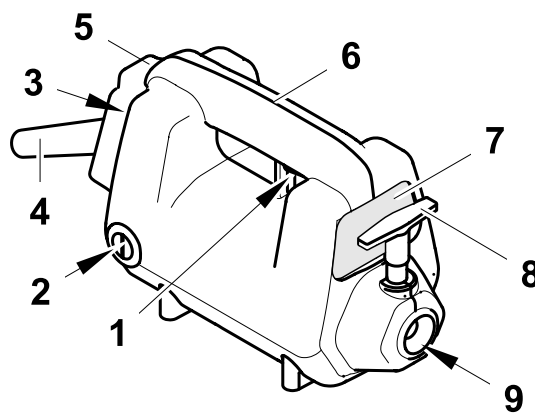

Item	Designation	Item	Designation
1	ON/OFF switch	6	Handle
2	Carbon brushes (2 pieces)	7	Ventilation grill
3	Ventilation slots	8	Quick disconnect coupler
4	Power cable	9	Connection to flexible shaft
5	Air cleaner		

Quick disconnect coupler

The quick disconnect coupler is a secure combination of the flexible shaft to the drive and enables a fast change of the flexible shaft.

Carbon brushes

The carbon brushes wear out during operation. If the carbon brushes are below the minimum length, the motor shuts off automatically.

Air cleaner

The air cleaner protects the motor from contamination.

An air stream enters the drive housing through the air cleaner, cools the motor and leaves through the ventilation grill.

5.4 Flexible shaft components

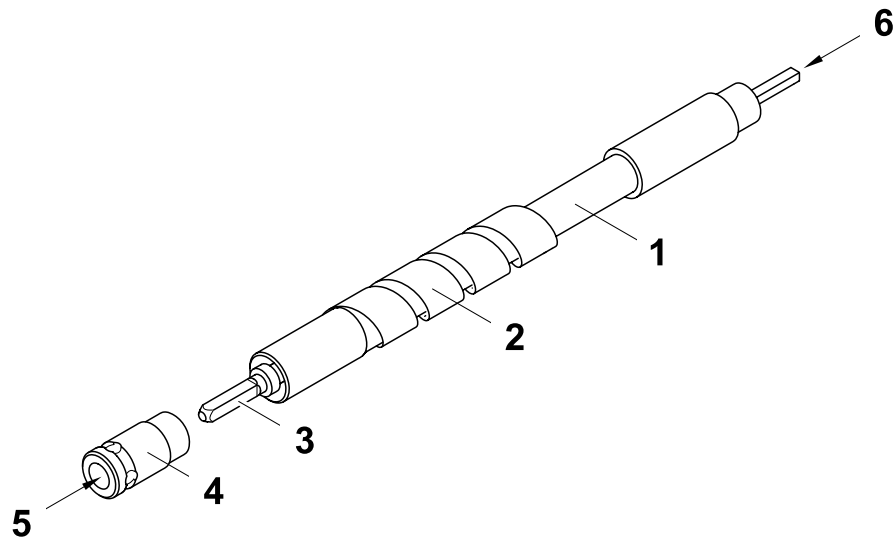

Item	Designation	Item	Designation
1	Protective hose	4	Coupling
2	Bend protection	5	Connection to drive
3	Shaft core	6	Connection to vibrator head

5.5 Vibrator head components

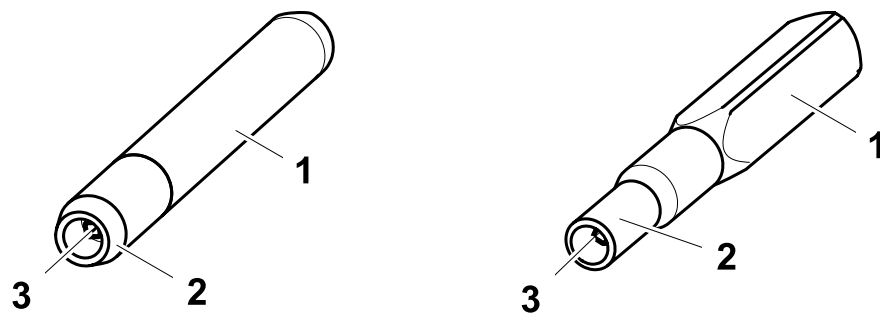

Item	Designation	Item	Designation
1	Housing	3	Shaft core adapter
2	Connecting piece		

6 Transport

Transporting the machine

1. Switch off the engine.
2. Wait until the machine has come to a complete standstill.
3. Pull the plug from the plug receptacle.
4. Remove the flexible shaft from the drive.
5. Allow motor and vibrator head to cool down.
6. Place all components on a suitable means of transport.
7. Roll up the power cable.
Note: Do not kink the power cable!
8. Secure all components against falling or sliding.

7 Operation



WARNING

Improper handling can result in injury or serious material damage.

- ▶ Read and follow all safety instructions of this operator's manual, see chapter *Safety information*.
-



WARNING

Leakage current due to permeating moisture.

Injuries from electrocution.

- ▶ In moist environment keep or set the machine in operative position.
 - ▶ Use extension cable of IPx4 design, so that the plug/coupling connection is protected from spraying water.
-

7.1 Prior to starting the machine

After unpacking, the machine is ready for operation.

Plug

The machine comes with a country-specific plug as a standard equipment.

Note on the version without mains plug (non-EU countries)



DANGER

Improper assembly of plug.

Danger of electrocution.

- ▶ Only a qualified electrician is permitted to assemble the plug and perform a subsequent safety check according to the directives in effect.
 - ▶ Observe the assembly instructions.
-

Carrying out checks

- ▶ Check if mains or power distribution on the construction site have the correct operating voltage (see nameplate of the machine or chapter *Technical Data*).
- ▶ Check if mains or power distribution on the constructions site are protected in accordance with current standards and regulations.

7.2 Mounting the vibrator head



WARNING

Rotating parts.
Risk of injury to hands.

- ▶ Shut off drive.
- ▶ Disconnect the flexible shaft from the drive.

Screwing the flexible shaft on the vibrator head

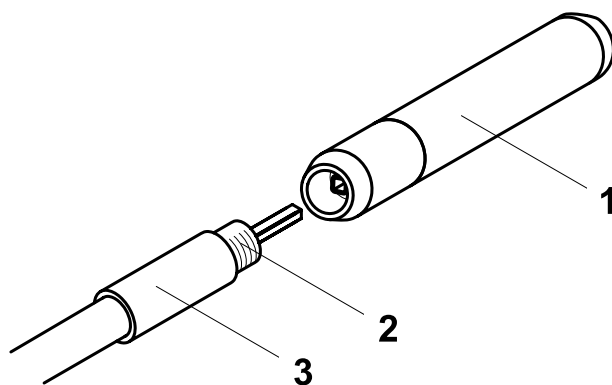

Item	Designation	Item	Designation
1	Vibrator head	3	Flexible shaft
2	Thread		

1. Clamp flexible shaft in a vice with prism jaws.
2. Place pipe thread seal on the thread of the flexible shaft.
3. Place the vibrator head with the thread on the flexible shaft, while guiding the shaft core into the shaft core adapter of the vibrator head.
4. Screw the vibrator head on the flexible shaft (Caution! Left-hand thread) and tighten with large pipe wrench.
5. Let pipe thread seal cure for 24 hours.

Coupling the flexible shaft to the drive

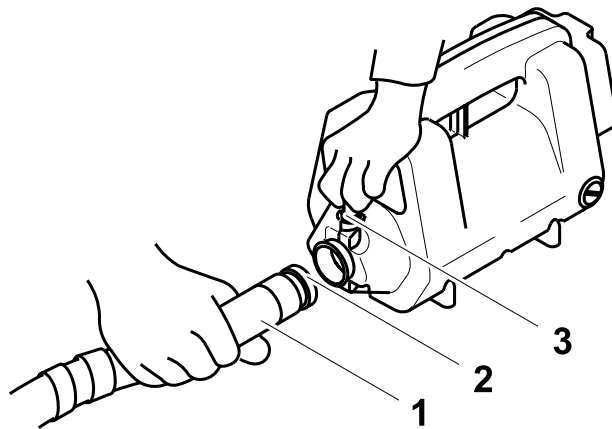

Item	Designation
1	Flexible shaft
2	Coupling
3	Quick disconnect coupler

1. Set drive upright on the floor.
Drive must be shut off.
2. Lift quick disconnect coupler.
3. Stick the flexible shaft coupling in the drive coupling, while guiding the shaft core in the shaft core adapter of the drive.
4. Guide the flexible shaft coupling until it stops.
5. Release the quick disconnect coupler.
6. Turn the flexible shaft until the quick disconnect coupler engages.
7. Control whether the quick disconnect coupler is completely engaged by pulling on the flexible shaft.

Note: If the flexible shaft core is new, the drive must run approx. 5 minutes with the flexible shaft connected (if necessary with the vibrator head as well).

7.3 Starting up

Connecting the machine to the power supply

NOTICE

Electrical voltage.

Incorrect voltage can cause damage on the machine.

- ▶ Check if the voltage of the current source corresponds with the information of the machine, see chapter *Technical Data*.
-



WARNING

Electrical voltage.

Injuries from electrocution.

- ▶ Check power cable and extension cable for signs of damage.
 - ▶ Only use extension cables for which grounded conductors are connected to the plug and the coupling (only for machines of class rating I).
-

1. Turn off ON/OFF switch.

Note: When the ON/OFF switch is pressed, the machine starts to run immediately at the connection. The machine can strike out and may injure persons or be damaged.

2. If required, connect a permitted extension cable to the power cable of the machine.

Note: See chapter *Technical data* for the permitted lengths and cross-section areas of extension cables.

3. Insert the plug into the plug receptacle.

Switching on the machine

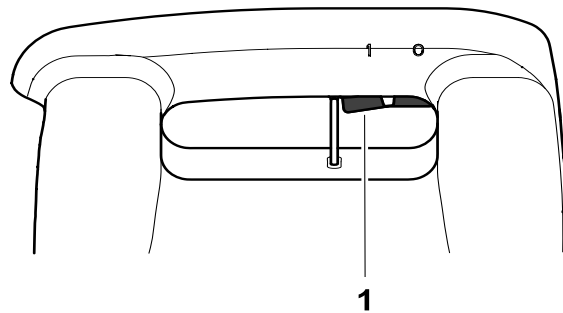

Item	Designation
1	ON/OFF switch

1. Lift vibrator head from floor with protective hose, to prevent damage to the machine or foundation.
2. Switch on the machine via the ON/OFF switch.

Compacting fresh concrete

1. Quickly immerse the vibrator head in the fresh concrete, hold it for several seconds and slowly pull it out again.
2. Immerse the vibrator head in all areas of the formwork and compact the fresh concrete.

Note:

- Compact especially intensively in corner areas and the formwork because of the high reinforcement.
- Make sure that the vibrator head does not touch the reinforcement. Damages can occur both on the vibrator head and also on the concrete, if it is already in the curing process.
- The holding time of the vibrator head in the concrete depends on the diameter of the vibrator head, the consistency of the concrete and the layer thickness.
- Indications that the concrete is sufficiently compacted:
 - The concrete no longer sets.
 - Air bubbles no longer or rarely rise.
 - The sound of the vibrator head is not changing anymore.

7.4 Decommissioning

Switching off the machine

NOTICE

The vibrator head moves if it is turned on and not immersed in the fresh concrete.

Danger of injury or danger of damage to property by uncontrolled vibrator head.

- ▶ Switch the machine off before you put it down.
-

NOTICE

The vibrator head heats up if it is turned on and not immersed in the fresh concrete.

Hot surface can cause burns.

Damage to the machine with excessive wear.

- ▶ Do not operate the machine with the internal vibrator not immersed in the fresh concrete.
-

1. Slowly remove the machine from the fresh concrete; hold the vibrator head in the air.
2. Switch off the machine via the ON/OFF switch.
3. Wait until the machine has come to a complete standstill.
4. Put down the machine slowly.

Note: Do not kink the protective hose and power cable!

5. Pull the plug from the plug receptacle.

Disconnecting the flexible shaft from the drive

NOTICE

The coupling of the flexible shaft heats up during operation.

Hot surface can cause burns.

- ▶ Allow the coupling of the flexible shaft to cool before touching it.
-

1. Lift quick disconnect coupler.
2. Remove the flexible shaft coupling from the drive coupling.
3. Release the quick disconnect coupler.

Cleaning the machine

Clean the machine after each use.

1. Clean the vibrator head and protective hose with water.

Note: You can remove concrete residuals by immersing the running machine into gravel.

2. Wipe the drive with a damp and clean cloth.
3. Clean the ventilation grill with a suitable tool.

8 Maintenance



WARNING

Improper handling can result in injury or serious material damage.

- ▶ Read and follow all safety instructions of this operator's manual, see chapter *Safety information*.
-



WARNING

Electrical voltage.

Injuries from electrocution.

- ▶ Remove the plug from the plug receptacle before all work on the machine.
-

8.1 Maintenance schedule

Note: The time intervals mentioned here are reference values for normal operation. For extreme operation, e.g. continuous use, the service intervals should be halved.

Task	Daily before operation	Every 50 hrs.	Every 100 hrs.	Every 300 hrs.
Check power cable for perfect condition – if power cable is defective, have it replaced.	■			
Visual inspection of all parts for damage.	■			
Clean drive: - Air inlet on air cleaner. - Air exit on ventilation grill.	■			
Check that the connections are tight: - Flexible shaft – vibrator head: Tighten if necessary. - Flexible shaft – drive: If necessary, securely engage the coupling.	■			
Clean air cleaner.		■		
Check carbon brushes – replace if necessary.		■		
Check wear dimensions of the vibrator head.		■		
Lubricate flexible shaft and replace plastic bushing.			■	
Change oil in vibrator head.				■

Notify your WACKER contact in case of maintenance work which you cannot or may not complete yourself.

8.2 Maintenance work

Work in the workshop

Perform maintenance work in a workshop on a workbench. This has the following benefits:

- Protection of the machine of contamination on the construction site.
- A level and clean work surface makes work easier.
- There is a better overview over small parts and they are not lost as easily.

8.2.1 Visual inspection

Checking the machine



WARNING

A damaged machine part or power cable can result in personal injury caused by electric current.

- ▶ Do not operate a damaged machine.
 - ▶ Have a damaged machine repaired immediately.
-

- ▶ Check all machine components for damage or cracks.

8.2.2 Drive

Cleaning the air cleaner

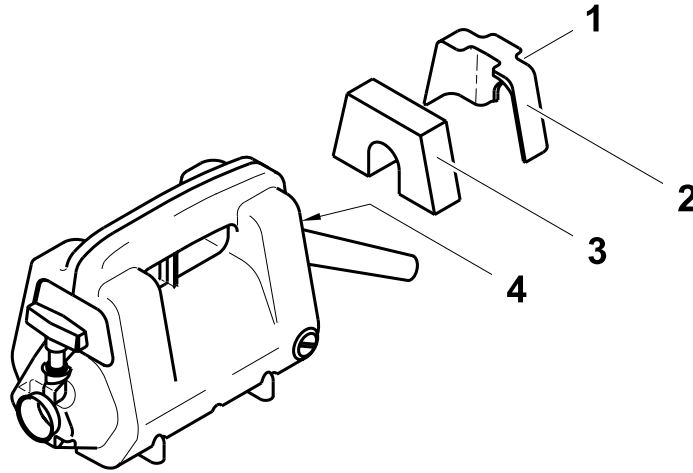

Item	Designation	Item	Designation
1	Allen screw	3	Air cleaner
2	Air cleaner cap	4	Ventilation slots

1. Unscrew Allen screw with correct wrench (5 mm) and remove air cleaner cap.
2. Remove air cleaner and wash with clean water.
Note: Replace air cleaner if it is very dirty.
3. Clean the ventilation slots with a suitable tool.
4. Insert dry air cleaner.
5. Replace air cleaner cap.
6. Screw Allen screw with correct wrench (5 mm) and hand tighten.

Checking/replacing the carbon brushes



WARNING

Improper replacement of parts.
 Danger of electrocution.

- ▶ Only a qualified electrician is permitted to replace parts and perform a subsequent safety check according to the directives in effect.

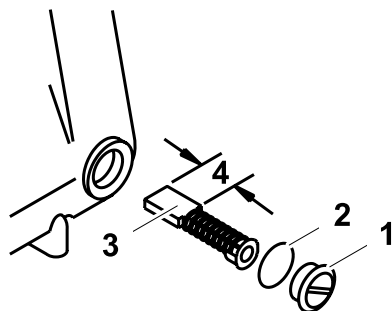

Item	Designation	Item	Designation
1	Cap	3	Carbon brushes
2	O-ring	4	Minimum length 10 mm (0.4 in)

Performing preparations

1. Pull the plug from the plug receptacle.
2. Remove any dirt around the cap.

Removing the carbon brushes

1. Unscrew the carbon brush caps (on both sides of the drive) with the correct screwdriver and remove with the o-ring.
2. Remove carbon brush.
3. Mark the position and location of the carbon brush with a pencil for reinstalling.

Checking the carbon brushes

- ▶ Check that both carbon brushes do not fall short of the minimum length.
Note: If at least one carbon brush is smaller than the minimum length, both carbon brushes must be replaced.

Inserting the carbon brushes

1. Install carbon brush (on both sides of drive).
Pay attention to the original position and location of used carbon brushes, to avoid damage and sparking on the collector.
2. Screw on cap with o-ring and tighten with a screwdriver hand tight.

Note: If you have installed new carbon brushes, the drive must be run for approx. 5 minutes without the flexible shaft attached.

8.2.3 Flexible shaft

Removing the shaft core

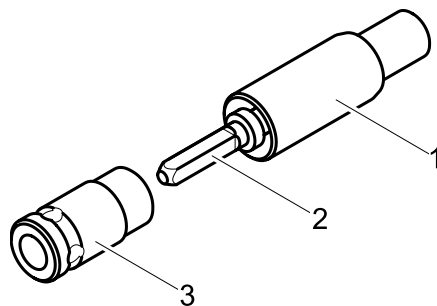

Item	Designation	Item	Designation
1	Flexible shaft	3	Coupling
2	Shaft core		

1. Remove any dirt around the coupling.
2. Clamp flexible shaft in a vice with prism jaws.
3. Unscrew coupling with large pipe wrench or special wrench (accessory).
4. Remove the shaft core completely from the protective hose.
5. Wipe off the shaft core with a clean, lint-free cloth.
Note: Do not clean the shaft core or the protective hose with solvent!
6. Clean the thread of the coupling and the flexible shaft with a wire brush and cleaning agent.

Replacing the plastic bushing

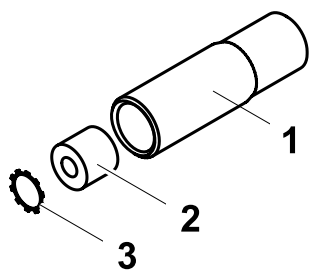

Item	Designation	Item	Designation
1	Flexible shaft	3	Retaining clip
2	Plastic bushing		

1. Remove retaining clip with a screwdriver.
2. Pull out plastic bushing with a pulling tool if necessary.
3. Wipe off bearing surface with a clean, lint-free cloth.
4. Push in a new plastic bushing.
5. Place the retaining clip on with the concave side to the inside, until all the teeth engage in the groove.

Lubricating the shaft core

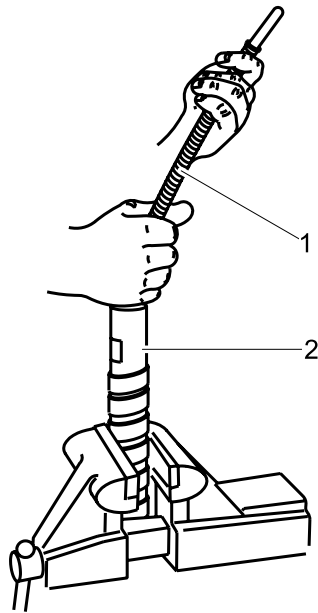

Item	Designation
1	Shaft core
2	Protective hose

Note: If the flexible shaft is damaged or has grooves, the flexible shaft must be replaced.

- ▶ Lubricate the shaft core thinly and uniformly with special lubricant (accessories) using your hands.

Assembling the flexible shaft

1. Insert the shaft core completely in the protective hose while turning. Turning the shaft core lubricates the special lubricant.
2. Guide the shaft core in the shaft core adapter of the vibrator head.
3. Place pipe thread seal (accessory) on the thread of the coupling.
4. Screw the coupling onto the flexible shaft and tighten with large pipe wrench or special wrench (accessory).
5. Check the shaft core for free movement, while turning with the special wrench (accessory).

Note: If the shaft core is new, the drive must run approx. 5 minutes with the flexible shaft connected (if necessary with the vibrator head as well).

8.2.4 Vibrator head

Checking wear dimensions of the vibrator head

Wear dimensions:

- Vibrator head minimum diameter (H vibrator head).
- Minimum width across flats (HA vibrator head).

Wear is highest at the end of the vibrator head.

Let the lower tube be exchanged by your WACKER contact if the wear dimensions are reached at a certain point.

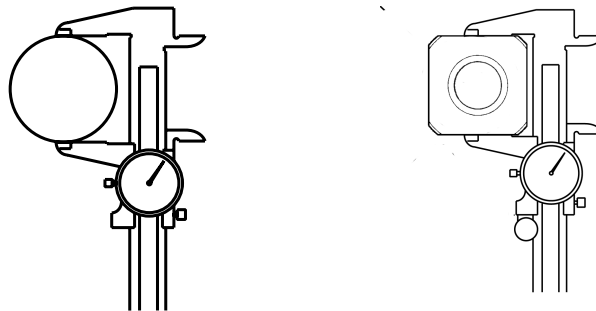

Vibrator head	Wear dimension		Original dimension	
	[mm]	[in]	[mm]	[in]
H 25, H 25S	24.0	0.94	25.0	0.98
H 35, H 35S	32.0	1.26	35.0	1.38
H 45, H 45S	41.0	1.61	45.0	1.77
H 55	52.0	2.05	57.0	2.24
H 65	58.0	2.28	65.0	2.26
H 25HA	25.0	0.98	26.2	1.03
H 35HA	32.0	1.26	36.0	1.42
H 45HA	39.0	1.54	45.0	1.77
H 50HA	46.0	1.81	50.0	1.97

Changing the oil in the vibrator head

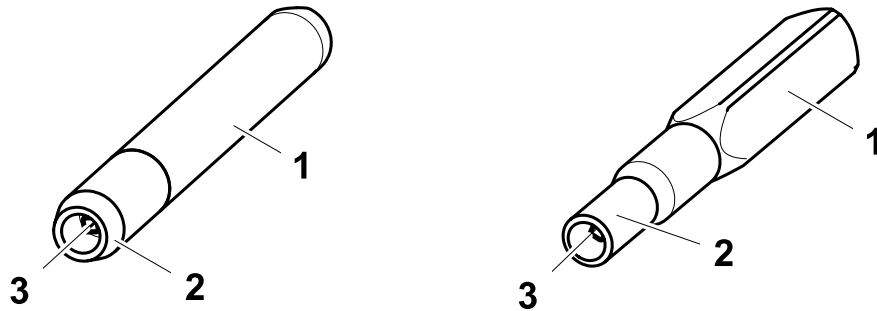

Item	Designation	Item	Designation
1	Housing	3	Shaft core adapter
2	Connecting piece		

Opening the vibrator head

1. Remove any dirt around the connecting piece.
2. Clamp flexible shaft in a vice with prism jaws.
3. Unscrew the vibrator head from the flexible shaft with a large pipe wrench (Caution! Left-hand thread).
4. Clean the thread of the vibrator head and the flexible shaft with a wire brush and cleaning agent.
5. Clamp the vibrator head in the area of the connecting piece.
6. Unscrew the housing from the connecting piece with a large pipe wrench.

Changing the oil

1. Pour out oil and dispose of environmentally friendly.
2. Clean the threads of the connecting piece and the vibrator head with a wire brush and cleaning agent.
3. Fill oil in the housing according to specification and in the correct amount, see chapter *Technical Data*.

Assembling the vibrator head

1. Place pipe thread seal on the thread of the housing.
2. Screw the housing on the connecting piece and tighten with a large pipe wrench.
3. Place pipe thread seal on the thread of the flexible shaft.
4. Place the vibrator head with the thread on the flexible shaft, while guiding the shaft core into the shaft core adapter of the vibrator head.
5. Screw the vibrator head on the flexible shaft (Caution! Left-hand thread) and tighten with large pipe wrench.
6. Let pipe thread seal cure for 24 hours.

9 Troubleshooting

Potential faults, their causes and remedies can be found in the following table.

Malfunction	Cause	Remedy
Machine not in operation.	Power cable interrupted.	Check power cable, have it replaced if defective.
	Carbon brushes worn.	Replace carbon brushes.
	Fault current protective switch turned off.	Turn on fault current protective switch.
	ON/OFF switch defective.	Have ON/OFF switch replaced.
	Current voltage fuse triggered.	Activate fuse.
	Motor burned through.	Replace drive.
Machine cuts out.	Carbon brushes worn.	Replace carbon brushes.
Motor runs very loud.	Carbon brushes broken.	Replace carbon brushes.
	Drive bearing worn.	Have machine parts replaced.
	Rotor grinds on stator.	
Motor runs normally, but overheated.	Air cleaner, ventilation grill or ventilation slots are plugged.	Remove dirt, replace air cleaner if necessary.
	Too much special lubricant in the flexible shaft.	Remove excess special lubricant with a cloth.
	Too much oil in the vibrator head.	Remove excess oil.
Motor runs slow and overheats.	Input voltage too low.	Provide correct line voltage.
	Wire cross-section of extension cable is too small.	Use extension cable with sufficient wire cross-section.
	Incorrect combination of vibration head and flexible shaft.	Only use combination according to the table, see chapter <i>Technical Data</i> .
	Shaft core of the flexible shaft not sufficiently lubricated.	Lubricate shaft core.
	Vibrator head bearing or drive bearing worn.	Have machine parts replaced.
	Rotor grinds on stator.	

Notify your WACKER contact in case of malfunctions you cannot or may not remedy yourself.

10 Disposal

10.1 Disposal of the machine

Your machine contains many valuable raw materials which should be disposed and recycled in an environmentally friendly manner.

During disposal of the machine observe the country-specific rules and regulations, e.g. the European Directive for obsolete electrical and electronic devices.



Do not dispose of the machine in household rubbish. It must be disposed at a recycling facility.

11 Accessories

There is a wide range of accessories available for the machine.

For more information on the individual accessories, visit the following website:
www.wackergroup.com.

11.1 Special wrench for flexible shaft

The flexible shaft coupling can be removed easier with the special wrench.

11.2 Pipe thread seal

The pipe thread seal is needed for sealing the thread connection between the vibrator head and the flexible shaft, as well as between coupling and flexible shaft.

11.3 Special lubricant for flexible shafts

The WACKER special lubricant is needed for lubricating flexible shaft cores in the flexible shafts.

11.4 SS-adapter

The SS-adapter is used to connect two S-flexible shafts.

NOTICE

Motor overload.

Flexible shafts which are too long can overload the motor.

► Keep a total length of 9 m (29.6 ft).

Various lengths of flexible shafts is found in the *Technical Data* chapter.

11.5 Carrying belt

You can carry the drive with the carrying belt, if you must often change position.

12 Technical data

12.1 Drive

Note: All drives are double insulated. In addition, some models have a grounded conductor connection.

M motor 230 V

Designation	Unit	M 1000	M 2000	M 3000	
Item no.		0005494	0005495	0006590	0005800
Housing color		Green	Yellow	Red	
Length x Width x Height	mm (in)	350 x 160 x 200 (13.8 x 6.3 x 7.9)	350 x 160 x 200 (13.8 x 6.3 x 7.9)	350 x 160 x 200 (13.8 x 6.3 x 7.9)	
Operating weight	kg (lb)	5.7 (12.6)	6.4 (14.1)	8.4 (18.5)	7.9 (17.4)
Rated voltage	V	230 1~			
Rated frequency	Hz	50–60			
Rated power consumption	kW	1.06	1.33	2.13	
Rated current consumption	A	4.5	6.5	10.0	
Rated speed	rpm	15,500	17,500	16,500	
Drive motor		Universal electric motor			
Class rating *		II			I
Protection class **		IP24			
Minimum length of the carbon brushes	mm (in)	10.0 (0.4)			

* According to DIN EN 61140, description see [12.5 Notes regarding class rating and protection class](#) (page 46).

** According to DIN EN 60529, description see [12.5 Notes regarding class rating and protection class](#) (page 46).

M motor 110-125 V

Designation	Unit	M 1000	M 2000		M 3000
Item no.		0005843	0007159	0007653	0005845
Housing color		Green	Yellow		Red
Length x Width x Height	mm (in)	350 x 160 x 200 (13.8 x 6.3 x 7.9)			
Operating weight	kg (lb)	5.3 (11.7)	6.0 (13.2)	6.2 (13.7)	8.1 (17.9)
Rated voltage	V	110–125 1~			
Rated frequency	Hz	50–60			
Rated power consumption	kW	1.06	1.56		2.13
Rated current consumption	A	9.0	15.0		20.0
Rated speed	rpm	15,500	17,500		16,500
Drive motor		Universal electric motor			
Class rating *		I			
Protection class **		IP24			
Minimum length of the carbon brushes	mm (in)	10.0 (0.4)			

* According to DIN EN 61140, description see [12.5 Notes regarding class rating and protection class](#) (page 46).

** According to DIN EN 60529, description see [12.5 Notes regarding class rating and protection class](#) (page 46).

12.2 Noise and vibration figures

Designation	Unit	HMS
Sound pressure level L_{pA} at operator's station *	dB(A)	85
Sound power level L_{WA} **	dB(A)	96
Total vibration value of the acceleration a_{hv} ***	m/s^2	5

* According to ISO 6081

** According to ISO 3744

*** Determined according to DIN EN ISO 5349, measured at a distance of 2 m (6.6 ft) from the lower tube, freely suspended in the air, at nominal speed.

12.3 Flexible shafts

S-flexible shafts

Designation	Unit	SM0-S	SM1-S	SM2-S	SM3-S
Length	m (ft)	0.5 (1.6)	1.0 (3.3)	2.0 (6.6)	3.0 (9.8)
Weight	kg (lb)	1.3 (2.9)	2.7 (5.9)	4.3 (9.5)	5.9 (13.0)

Designation	Unit	SM4-S	SM5-S	SM7-S	SM9-S
Length	m (ft)	4.0 (13.1)	5.0 (16.4)	7.0 (23.0)	9.0 (29.5)
Weight	kg (lb)	7.1 (15.7)	9.3 (20.5)	12.9 (28.4)	15.1 (33.3)

E-flexible shafts

Designation	Unit	SM1-E	SM2-E	SM4-E
Length	m (ft)	1.0 (1.6)	2.0 (6.6)	4.0 (13.1)
Weight	kg (lb)	1.5 (3.3)	2.5 (5.5)	4.3 (9.8)

12.4 Vibrator head

Standard vibrator head

Designation	Unit	H25	H25S	H35	H35S
Diameter	mm (in)	25 (1.0)	25 (1.0)	35 (1.4)	35 (1.4)
Length	mm (in)	440 (17.3)	295 (11.6)	410 (16.1)	310 (12.2)
Weight	kg (lb)	1.3 (2.9)	0.8 (1.8)	2.1 (4.6)	1.6 (3.5)
Oil quantity	ml (oz)	10 (0.3)	10 (0.3)	15 (0.5)	15 (0.5)
Oil specification		SAE 0W-30 (API SF or superior)			

Designation	Unit	H45	H45S	H55	H65
Diameter	mm (in)	45 (1.8)	45 (1.8)	57 (2.2)	65 (2.6)
Length	mm (in)	385 (15.2)	305 (12.0)	410 (16.1)	385 (15.2)
Weight	kg (lb)	3.4 (7.5)	2.8 (6.2)	5.4 (11.9)	6.8 (15.0)
Oil quantity	ml (oz)	22 (0.7)	19 (0.6)	30 (1.0)	44 (1.5)
Oil specification		SAE 0W-30 (API SF or superior)			

HA vibrator head

Designation	Unit	H 25HA	H 35HA	H 45HA	H 50HA
Width across flats	mm (in)	26 (1.0)	36 (1.4)	45 (1.8)	50 (2.0)
Length	mm (in)	380 (15.0)	405 (15.9)	390 (15.4)	395 (15.6)
Weight	kg (lb)	1.3 (2.9)	2.3 (5.1)	3.3 (7.3)	3.9 (8.6)
Oil quantity	ml (oz)	10 (0.3)	20 (0.7)	30 (1.0)	50 (1.7)
Oil specification		SAE 0W-30 (API SF or superior)			

12.5 Notes regarding class rating and protection class

Class rating

The class rating according to DIN EN 61140 specifies the safety measures for electrical equipment to avoid electrocution. There are four class ratings:

Class rating	Meaning
0	No special protection apart from the basic insulation. No grounded conductor. Plug connection without grounded conductor contact.
I	Connection of all conductive housing components to the grounded conductor. Plug connection with grounded conductor contact.
II	Reinforced or double insulation (protective insulation). No connection to the grounded conductor. Plug connection without grounded conductor contact.
III	Equipment is operated on protective low voltage (< 50 V). Connection to the grounded conductor is not necessary. Plug connection without grounded conductor contact.

Protection class IP

The protection class according to DIN EN 60529 indicates the suitability of electrical equipment for use in certain ambient conditions as well as the protection against risks.

The protection class is specified by an IP code according to DIN EN 60529.

Code	Meaning
IP	Code letter <i>International Protection</i>
2	1 st code number for protection from contact and foreign bodies: Protected against contact with one finger. Protected against medium-sized foreign objects (diameter > 12.5 mm (0.5 in)).
4	2 nd code number for protection from water and moisture: Protected against spraying water from all directions.

12.6 Extension cable

**WARNING**

Electrical voltage.
Danger of electrocution!

- ▶ Only use extension cables for which grounded conductors are connected to the plug and the coupling (only for machines of class rating I).

Refer to the following table for the required cross-section area of cable for a designated extension.

Note: Refer to the nameplate or the chapter *Technical data* (via the item number) for the type designation and voltage rating of your machine.

Machine	Voltage [V]	Extension [m]	Cross-section area of cable [mm ²]
M 1000	110 – 125	< 33	1.5
		< 55	2.5
		< 88	4.0
	230	< 133	1.5
		< 150	2.5
	M 2000	110 – 125	< 20
< 33			2.5
< 53			4.0
230		< 92	1.5
		< 150	2.5
M 3000		110 – 125	< 25
	< 40		4.0
	230	< 60	1.5
		< 100	2.5

Extension cable for the US market:

Machine	Voltage [V]	Extension [ft]	Cross-section area of cable [AWG]
M 1000	110 – 125	< 96	16
		< 151	14
		< 239	12
M 2000	110 – 125	< 57	16
		< 91	14
		< 143	12
		< 227	10
M 3000	110 – 125	< 68	14
		< 107	12
		< 170	10

Example

You utilize a M2000/110 - 125 V and want to use an extension cable with a length of 25 m (80 ft).

The machine has an input voltage of 110 – 125 V.

According to the table, the extension cable must feature a cross-section area of 2.5 mm² (AWG 14).

Note: Only use extension cables > 5 m (17 ft).

12.7 Allowable Drive - Flexible Shaft - Vibrator Head combinations

NOTICE

A vibrator head which is too large or flexible shaft which is too long overloads the drive.

Excessive wear and damage of the components is possible.

- ▶ Only use allowable combinations of components.
-

Vibrator head	Drive	Flexible shafts		
		SM1-E	SM2-E	SM4-E
H 25	M 1000	+	+	+
	M 2000	(+)	(+)	(+)
	M 3000	(+)	(+)	(+)
H 25S	M 1000	+	+	+
	M 2000	(+)	(+)	(+)
	M 3000	(+)	(+)	(+)
H 25HA	M 1000	+	+	+
	M 2000	+	+	+
	M 3000	+	+	+

Explanation:

- + This combination is allowed.
- (+) This combination is allowed, but not recommended.
- This combination is not allowed.

Vibrator head	Drive	Flexible shafts							
		SM0-S	SM1-S	SM2-S	SM3-S	SM4-S	SM5-S	SM7-S	SM9-S
H 35	M 1000	+	+	+	+	+	+	—	—
	M 2000	+	+	+	+	+	+	+	+
	M 3000	+	+	+	+	+	+	+	+
H 35S	M 1000	+	+	+	+	+	+	—	—
	M 2000	+	+	+	+	+	+	+	+
	M 3000	+	+	+	+	+	+	+	+
H 35HA	M 1000	—	—	—	—	—	—	—	—
	M 2000	+	+	+	+	+	+	+	+
	M 3000	+	+	+	+	+	+	+	+
H 45	M 1000	—	—	—	—	—	—	—	—
	M 2000	+	+	+	+	+	+	+	+
	M 3000	+	+	+	+	+	+	+	+
H 45S	M 1000	—	—	—	—	—	—	—	—
	M 2000	+	+	+	+	+	+	+	+
	M 3000	+	+	+	+	+	+	+	+
H 45HA	M 1000	—	—	—	—	—	—	—	—
	M 2000	+	+	+	+	+	+	+	+
	M 3000	+	+	+	+	+	+	+	+
H 50HA	M 1000	—	—	—	—	—	—	—	—
	M 2000	—	—	—	—	—	—	—	—
	M 3000	+	+	+	+	+	+	+	+
H 55	M 1000	—	—	—	—	—	—	—	—
	M 2000	+	+	+	+	+	+	+	+
	M 3000	+	+	+	+	+	+	+	+
H 65	M 1000	—	—	—	—	—	—	—	—
	M 2000	+	+	+	+	+	+	+	+
	M 3000	+	+	+	+	+	+	+	+

EC Declaration of Conformity

Wacker Construction Equipment AG, Preußenstraße 41, 80809 München certifies that the construction machines:

Category

Modular internal vibrator HMS

Type	M 1000	M 2000	M 3000
Machine type number	0005494	0005495 0007653	0006590

fulfill the requirements of the following directives:

98/37/EC

2006/95/EC

2004/108/EC

EN 61000

ppa *O Ha* *cl*

Dr. Stenzel

Head of Research and Development





Product Service

CERTIFICATE

No. U8 08 01 54130 002

Holder of Certificate: **Wacker Construction Equipment AG**

Preußenstr. 41
80809 München
GERMANY

Production Facility(ies):

64228

Certification Mark:

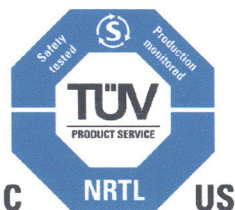

Product:

**Handheld electric tools
(Concrete vibrators)**

Model(s):

M1000/115/UL, M2000/115/UL, M3000/115/UL

Parameters:

Rated voltage:	110-125V ~
Rated frequency:	50-60Hz
Rated power:	1060W 1560W 2130W
Rated input current:	9A 15A 20A
Rated no-load speed:	15500/min 17500/min 16500/min
Class protection:	I
Degree of (water) protection:	IP 24

Remark: Modular internal vibrators for use with flexible shafts and bottles of different sizes.

Tested according to:

CAN/CSA-C22.2 NO. 60745-2-12-05
UL 60745-2-12:2005
The products are intended and certified for USA and Canada. Additional requirements may apply for other countries.

The product was voluntarily tested according to the relevant safety requirements and mentioned properties. It can be marked with the certification mark shown above. The certification mark must not be altered in any way. See also notes overleaf.

Test report no.:

034-322904-000

Date, 2008-01-11

Page 1 of 1



VDE Prüf- und Zertifizierungsinstitut

VDE VERBAND DER ELEKTROTECHNIK
ELEKTRONIK INFORMATIONSTECHNIK e.V.

CERTIFICATE

Registration-Number: 6236/QM/06.97

This is to certify that the company

WACKER



**Wacker Construction Equipment AG
Wacker-Werke GmbH & Co. KG**

at the following locations

**Head Office Munich
Preußenstraße 41
80809 Munich**

**Production plant Reichertshofen
Karlsfeld logistics centre
Sales regions with all branches all over Germany**

has implemented and maintains a
Quality Management System for the following scope:

**Machine manufacture
Construction machines**

This Q System complies with the requirements of

DIN EN ISO 9001:2000

and the requirements of the German and international Road Traffic Act.

This Certificate is valid until 2009-06-05.

VDE Testing and Certification Institute
Certification



Date: 2006-05-30

63069 Offenbach, Merianstraße 28
Telefon: +49 (0) 69 83 06-0, Telefax: +49 (0) 69 83 06-555
E-Mail: vde-institut@vde.com, <http://www.vde-institut.com>



The VDE Testing and Certification Institute is accredited by DAR Accreditation
Bodies according to DIN EN ISO 17020 and DIN EN ISO 45012 and notified in the EU
under ID.No. 0366.

TGA-ZM-09-92-00
KBA-ZM-A 00021-97

